

POLANIK
Poland, Życzliwa 11
97-300 Piotrków Trybunalski

tel. +48 44 646 44 81
tel. +48 44 648 50 89
fax +48 44 646 43 58

e-mail: info@polanik.com
www.polanik.com



USER MANUAL MEASURING SET TYPE ZP-S287



File: 2016-02-19

PRODUCT SUPPORT
Paweł Ciechanowski
p.ciechanowski@polanik.com

WZÓR ZASTRZEŻONY
REGISTERED DESIGN

Thank you for choosing POLANIK measuring set ZP-S287.

Contents

Chapter	Page
I. Characteristics and general description	2
II. Parts list	3
III. Preparing the set for measuring	4
IV. Measuring javelins	5
V. Measuring hammers	14
VI. Measuring shot puts	20
VII. Measuring discuses	22
VIII. Operation and maintenance	23

I. Characteristics and general description

ZP-S287 is designed for testing measurements of throwing implements (javelins, hammers, shot puts and discuses) if their dimensions comply with the rules of the International Association of Athletics Federations.

Main features:

- innovative construction – consists of elements which are easy to assemble and take little space, thanks to a specially designed carrying case the set is easy to transport and store
- measuring set ZP-S287 – registered design,
- easy operating – you can prepare the set for measuring very fast,
- high durability and high quality – elements are made of anodized aluminium, galvanized steel and high quality synthetic materials, they do not require any additional maintenance measures
- worn out elements are easy to replace.

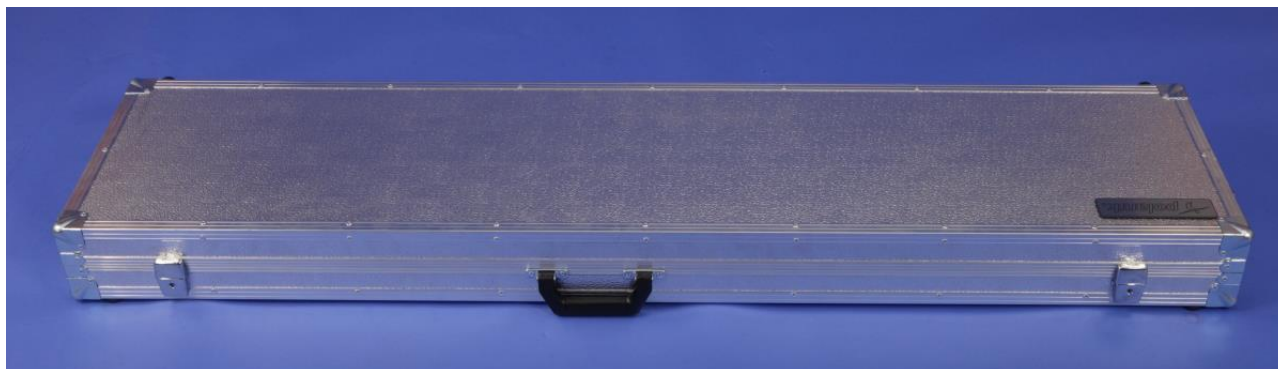

II. Parts list of measuring set ZP-S287

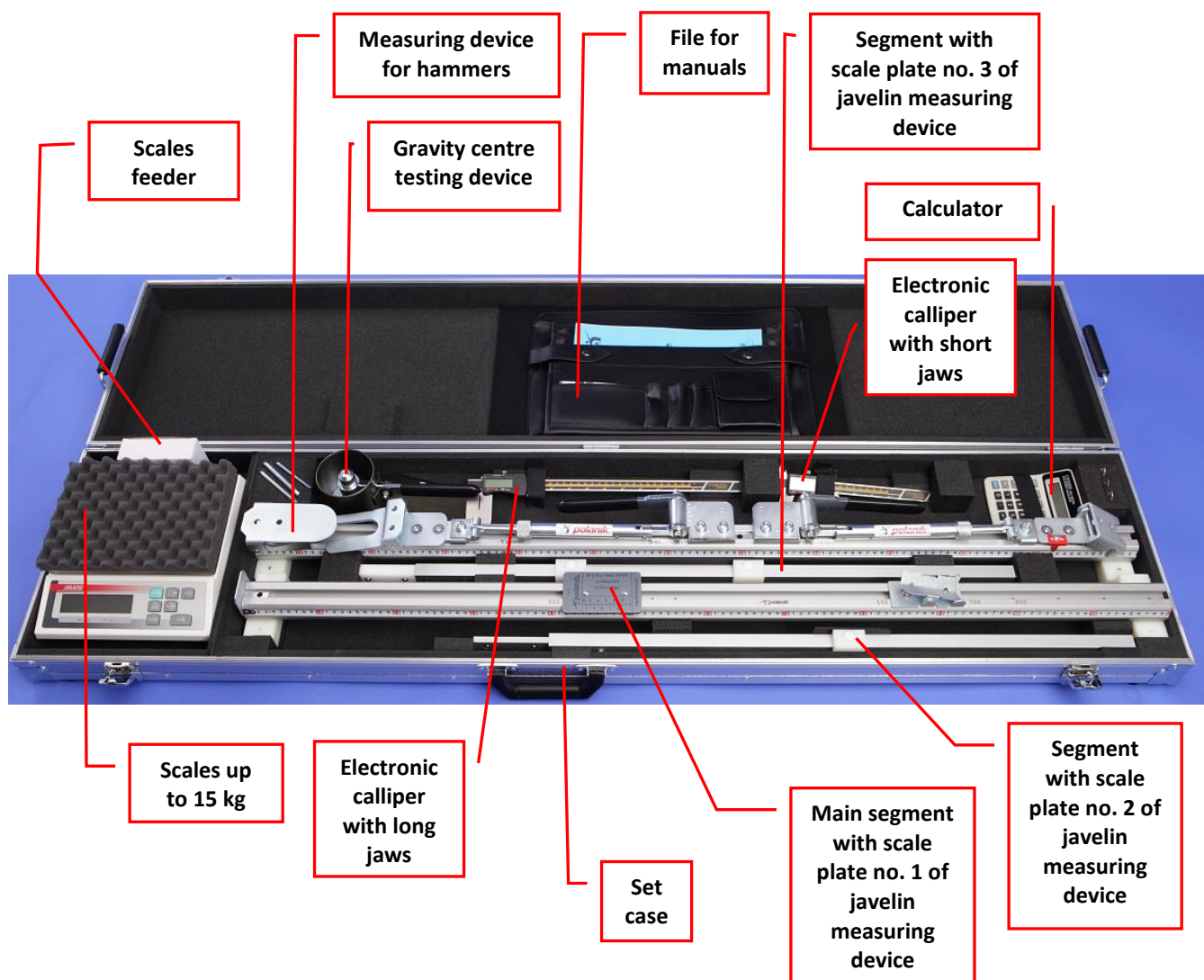

III. Preparing the set for measuring

The sequence of the assembly operations is described in detail in the instruction manual.

The measuring set ZP-S287 comes with the special sturdy case in which all the set elements are installed.

Before you start to test athletics implements the set case should be positioned on a flat and even surface, at the height of about 80 cm (on a table, piece of furniture, etc). The surface ought to be big enough to let the case lid rest freely on it. If you are going to measure javelins you should additionally provide about 1,7 m of free space on the right hand side of the set case for the segments of the javelin measuring device. It is recommended to use a special mobile stand S-289 (*available as an option*), which not only makes testing more comfortable, but also allows you to manoeuvre the set fast and safely.



Measuring and testing proceedings are done without taking out the devices from the set case, apart from the segments of the javelin measuring device and the callipers.

IV. Measuring javelins

The device is designed to measure only 500g, 600g, 700g and 800g javelins.



Before you start measuring the device should be assembled.



Please take out the device segment with scale plate no. 2 from the case and slide the left end of the segment into the main device part.



Next take out the device segment with scale plate no. 3 and slide its left end into the device segment with scale plate no. 2.

Now the device is ready for measuring.

You will also need to use the scales, the calliper with short jaws and the calculator to test javelins.

Javelin weight



Please weigh the javelin on the scales included in the set (see the instruction manual of the scales).

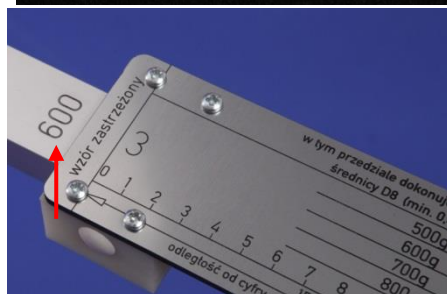
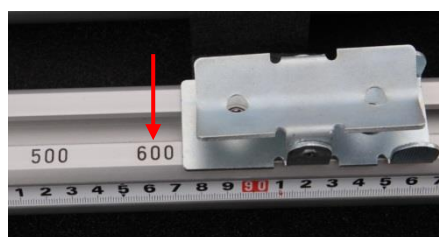

Now you know the javelin weight and you can position the scale plates (no. 1-3) and the device cradle at the corresponding weight marks (500g, 600g, 700g or 800g). The plates and the cradle must be positioned at the same weight.

The lengths and diameters which comply with the IAAF rules are presented in the table no. 1 (see page 14).

Javelin length

Now we shall measure the javelin length, provided that the scale plates and the cradle are positioned at the same weight value.



Place the javelin on the device cradle,

the stop of the javelin



and slide the javelin until it touches the stop,



now you can read the javelin overall length on the scale plate no. 3 **LO** (the javelin tail should end between minimum and maximum marked on the right scale of the plate no. 3 – the IAAF lengths are presented in the table no. 1, see page 14).

Next you can check other dimensions - do not change the position of the javelin.



Measure **D2** (the diameter of the javelin head 150 mm from the tip) with the calliper. The point in which **D2** is to be checked can be easily find with the measuring tape installed in the main device segment.

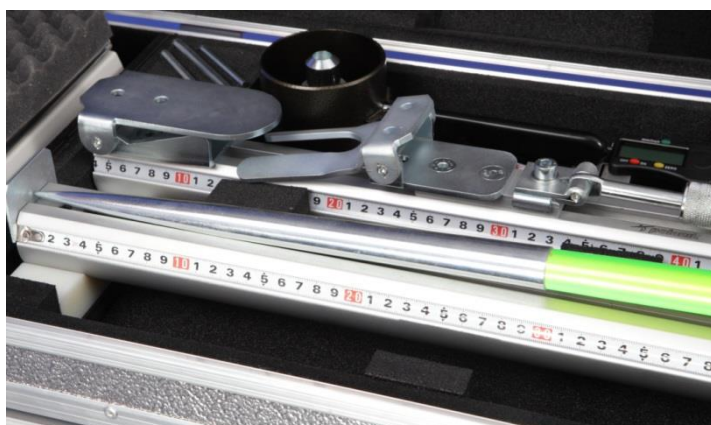

After that **L3** (the head length) can be read on the same built-in measuring tape,

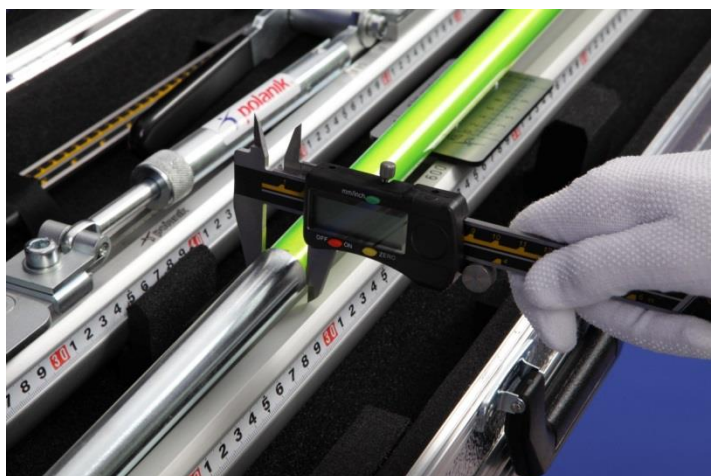

then **D3** (the diameter at the rear of the head) is measured with the calliper,

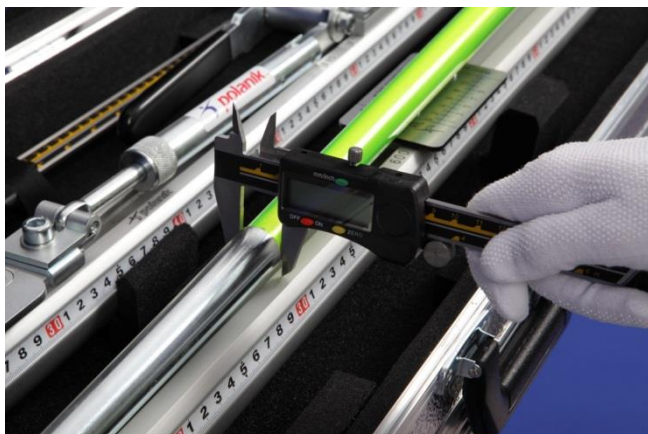

next **D4** (the diameter immediately behind the head) is measured with the calliper.



Moving towards the javelin tail, **D0** (the diameter in front of the grip) can be checked,



and **D6** (over the grip),

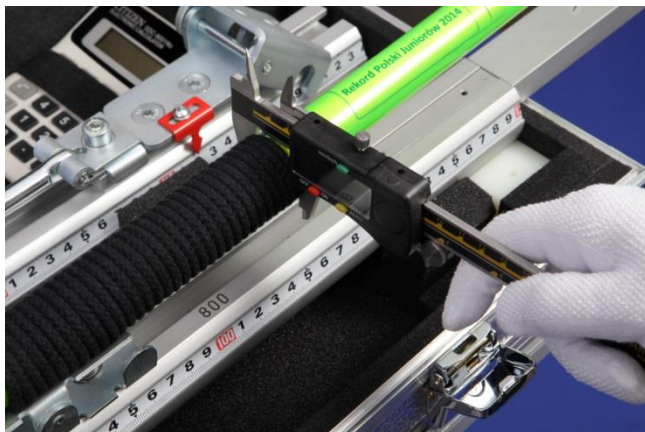

then in the same way we measure **D1** (the diameter at the rear of the grip).

Now we shall measure **D9** (the diameter at the tail) and **D8** (the diameter 150 mm from the tail). The scale plate no. 3 (shown below) has got two scales (one on the left side and the other on the right side). The distance between corresponding digits from the left scale and the right scale is 150 mm, so if the javelin tail ends at the digit 2 of the right scale, **D8** should be measured at the digit 2 of the left scale.

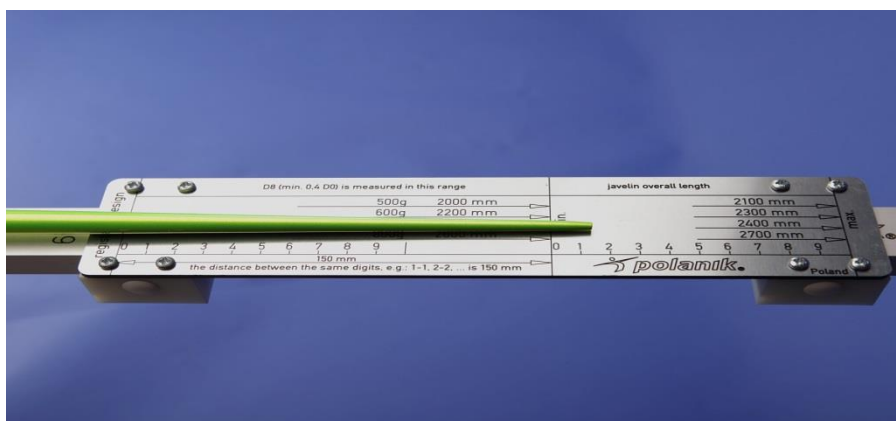

As you see this tail ends just after the digit 1 of the right scale,



so **D8** should be measured just after the digit 1 of the left scale.

Centre of gravity

For further measuring you need to find the javelin's centre of gravity, so slide the javelin very slowly to the right until it is balanced on the device cradle. That way we have the base upon which we can continue our test.

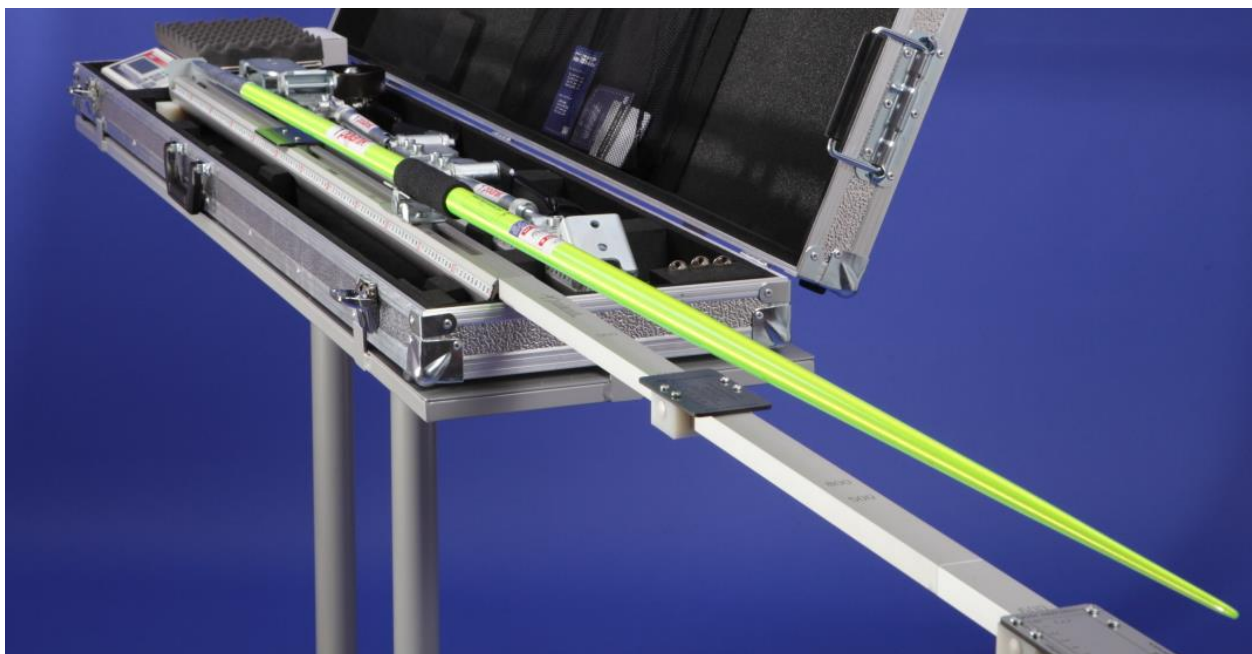

Other measurements: lengths and diameters

Having found the javelin's gravity centre we can calculate **L1** (the length from the tip to the centre of gravity) by subtracting the distance between the javelin tip and the stop from 1060 mm (for 800g javelins) or 1000 mm (for 700g javelins) or 920 mm (for 600g javelins) or 880 mm (for 500g javelins).

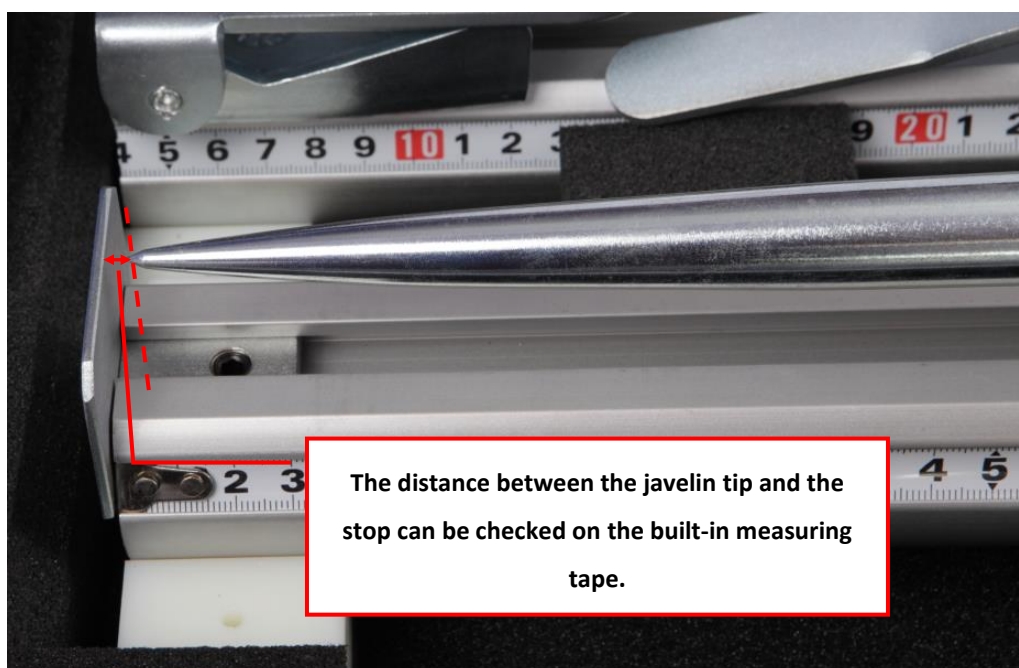

Next we shall find the point on the scale plate no. 1 at which **D5** (the diameter in the halfway **L1**) should be measured.

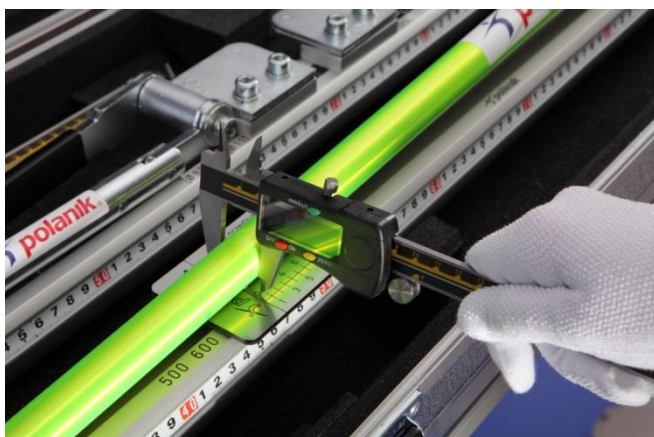

The digits on the scale plate no. 1 correspond to the distance between the tip and the stop. When the distance between the tip and the stop is 2 cm, **D5** should be measured at the digit 2 on the scale plate no. 1.

D7 is measured in the same way – the javelin is still balanced on the cradle.

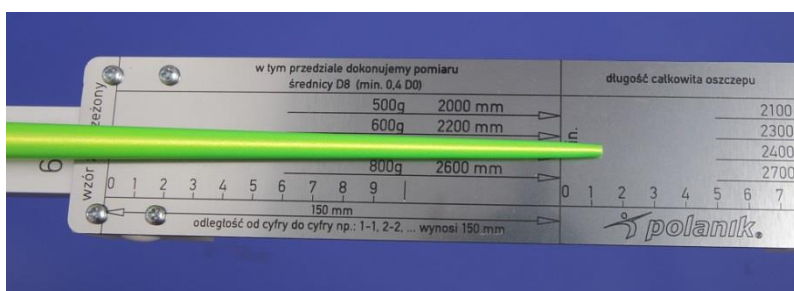

The position of the tail end is checked on the scale plate no. 3. For example, if the tail ends at the digit 4 of the scale plate no. 3,

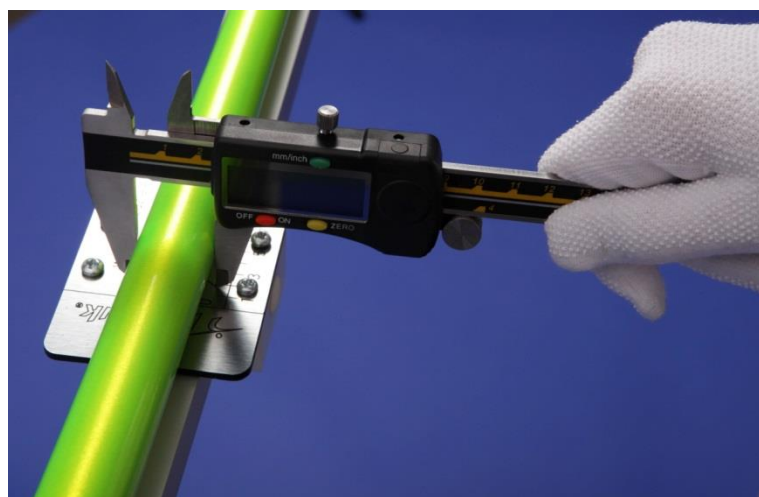

D7 should be measured at the digit 4 of the scale plate no. 2.

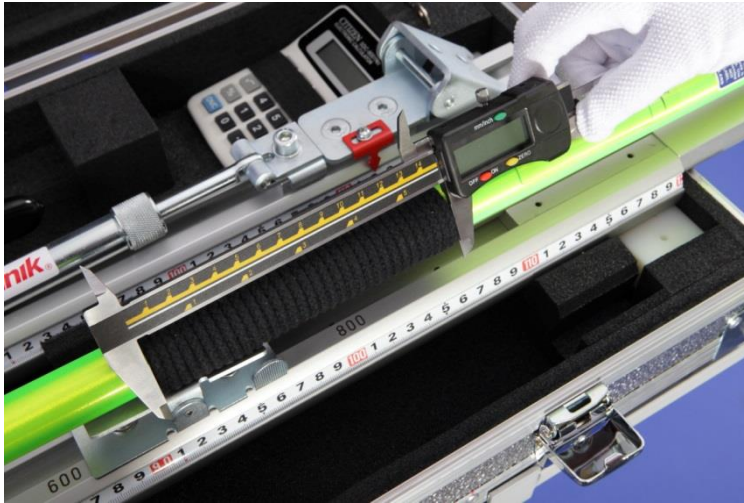

And now you can measure **L4** (the grip length).

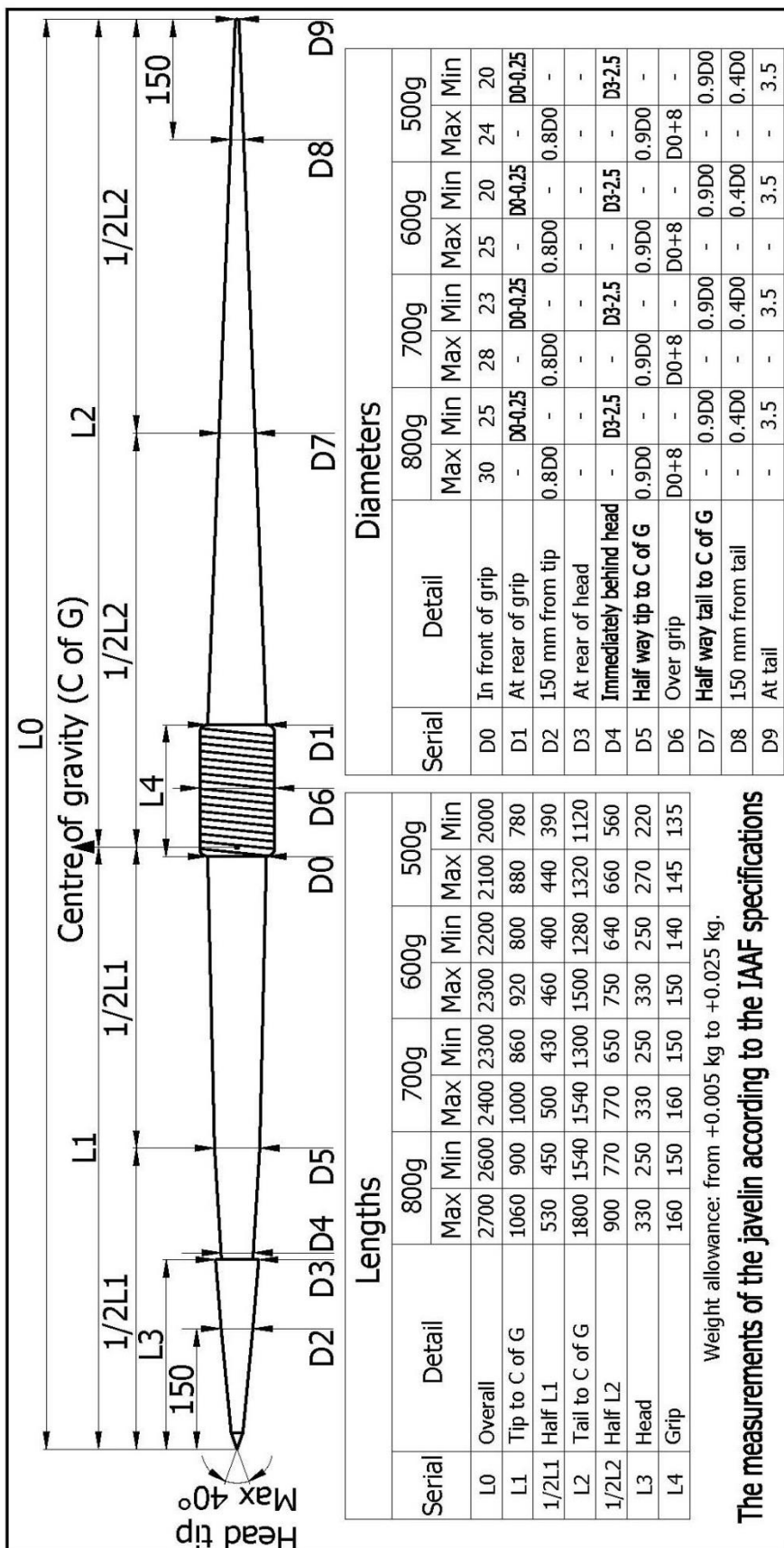
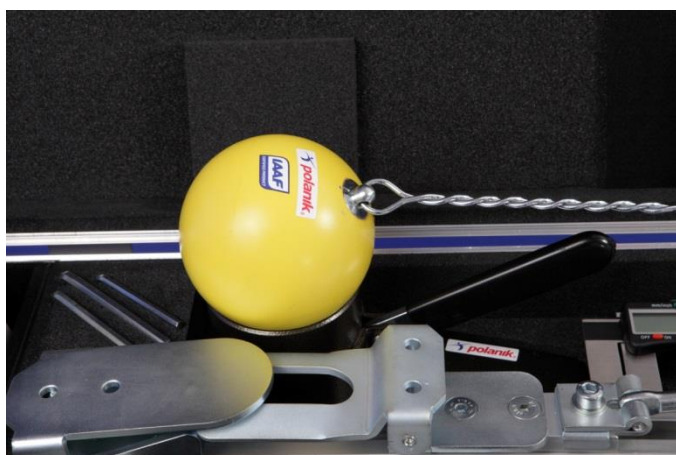

Table no. 1

V. Measuring hammers

For testing hammers we use:

- the electronic scales for checking the weight (see the instruction manual of the scales),
- the gravity centre testing device – see Table no. 2 on page 21,
- the calliper with long jaws – for measuring the head diameter,
- the calliper with short jaws – for measuring the hammer handle
- and the measuring device for hammers – for checking the length, see Table no. 2 on page 21.



Place the hammer head on the tester (see Table no. 2 on page 21),

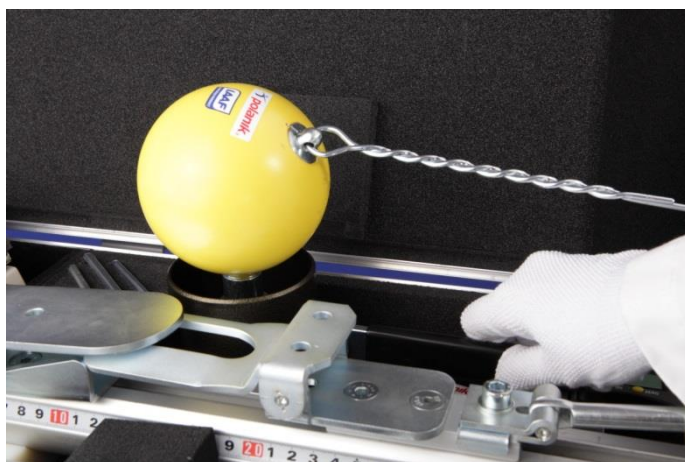

and press the lever all the way down - the steel sleeve (diameter 12 mm) lifts the head from the edge.

If the head stays on the sleeve, it complies with the IAAF rules concerning centre of gravity in hammer heads.

Now we shall check the overall length of the hammer with the measuring device.

Before you start measuring, the device should be set to its working position.

The measuring device is in its transport position when the case is closed, so before you measure a hammer you should:

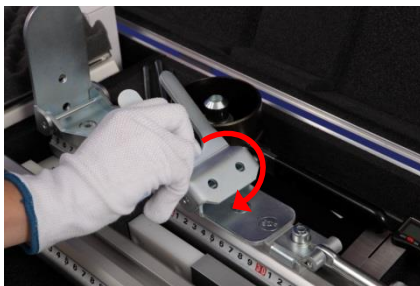

put the clamp jaws to upright position,



do the same with the handle catch,



next, put the levers to upright position, so that the clamping mechanism and the tightening mechanism are in initial point.



Now you ought to loosen the blocking screws of the mechanisms (two screws for each lever base) with the 6 mm hex key (included in the set).



Then slide the lever bases aside.



The lever base of the clamping mechanism is moved to the left. The edge of the lever base should be line up with the marked diameter which is the closest one to the diameter of the tested hammer.



The lever base of the tightening mechanism is moved to the right. The edge of the lever base should be lined up with the marked hammer length which is the maximal one mentioned in the IAAF rules for the weight of the tested hammer, for example if you are going to test 3 kg or 4 kg hammers the lever base edge should be lined up with the length 1195 (which is the maximal one for 3 kg and 4 kg hammers).



If you have positioned the lever bases, you have to tighten up the screws with the hex key. When the lever bases are blocked in the working positions, you can place the hammer on the device.

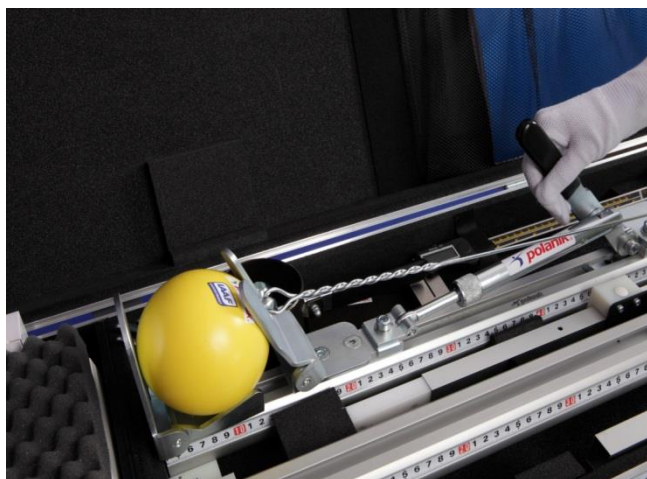

Now press the lever of the clamping mechanism all the way down until you feel resistance.



The hammer head is closed in the clamp.

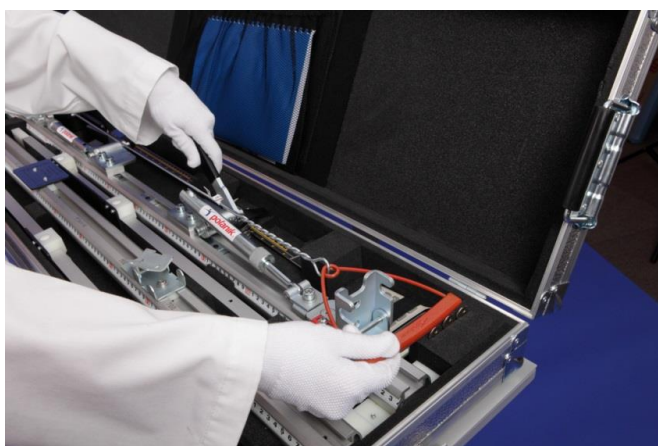

Now place the hammer handle in the catch, so that the catch is in the middle of the grip,



and press the lever of the tightening mechanism all the way down until you feel resistance.



When the wire is tight and the hammer is blocked,

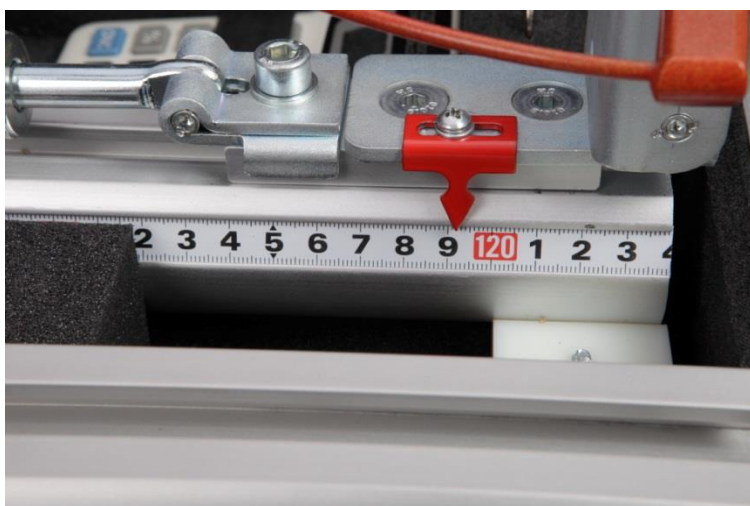

we can read its length which is marked by the red arrow indicator. The hammer lengths which comply with the IAAF rules are presented in the table no. 2, see page 21.

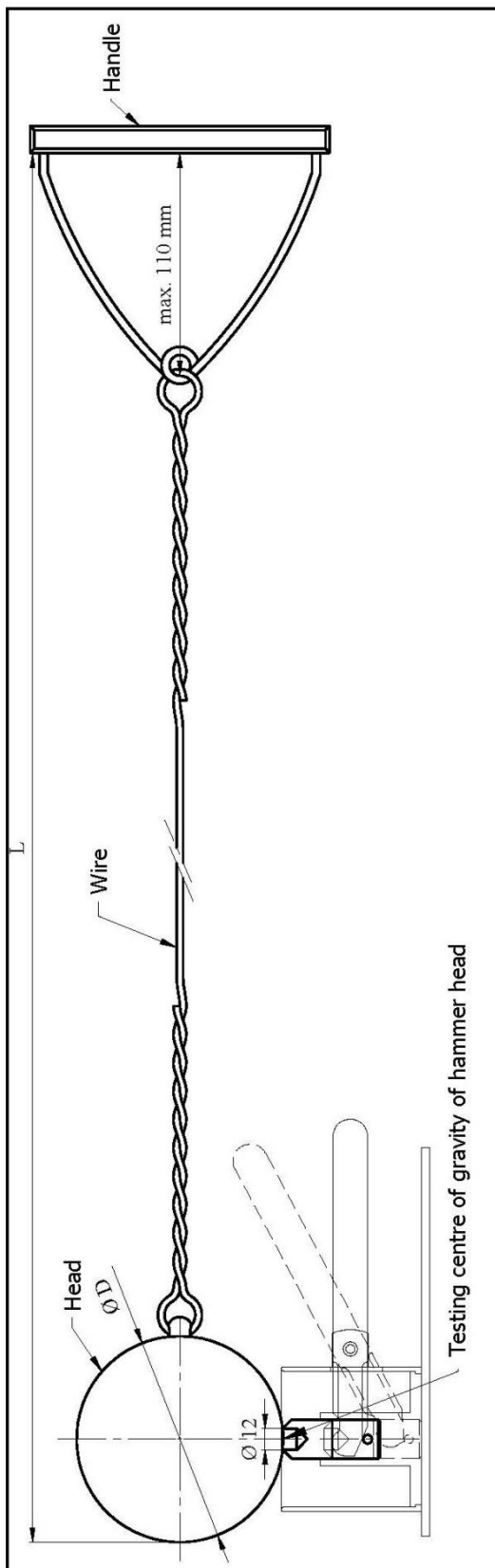

The hammer specifications according to the IAAF rules

Minimum weight for admission to competition and for acceptance of a record	3.000 kg		4.000 kg		5.000 kg		6.000 kg		7.260 kg	
	min.	max.	min.	max.	min.	max.	min.	max.	min.	max.
Information for manufacturers: Range for supply of implement for competition	3.005 kg	3.025 kg	4.005 kg	4.025 kg	5.005 kg	5.025 kg	6.005 kg	6.025 kg	7.265 kg	7.285 kg
Diameter of head [Ø D]	85 mm	100 mm	95 mm	110 mm	100 mm	120 mm	105 mm	125 mm	110 mm	130 mm
Length of hammer measured from inside of handle [L]	-	1195 mm	-	1195 mm	-	1200 mm	-	1215 mm	-	1215 mm

The centre of the head gravity must be situated not more than 6 mm from the centre of the sphere.
 The hammer head is tested, less the wire and the handle, on the horizontal sharp-edged circular orifice 12 mm in diameter.

Table no. 2

VI. Measuring shot puts

For testing shot puts we use:

- the electronic scales for checking the weight (see the instruction manual of the scales),
- the gravity centre testing device – (not required by the IAAF rules), see Table no. 3 on page 23,
- the calliper with long jaws – for measuring the diameter.

Although the IAAF rules do not mention any requirements concerning the gravity centre location in the shot put, its correct location is important for the safety of the athlete. The misplaced gravity centre in the shot may cause injuries. To check the shot's centre of gravity you should place the shot on the tester (see Table no. 3 on page 23), and press the lever all the way down - the steel sleeve (diameter 12 mm) lifts the shot from the edge. If the shot stays on the sleeve, it is correctly located.



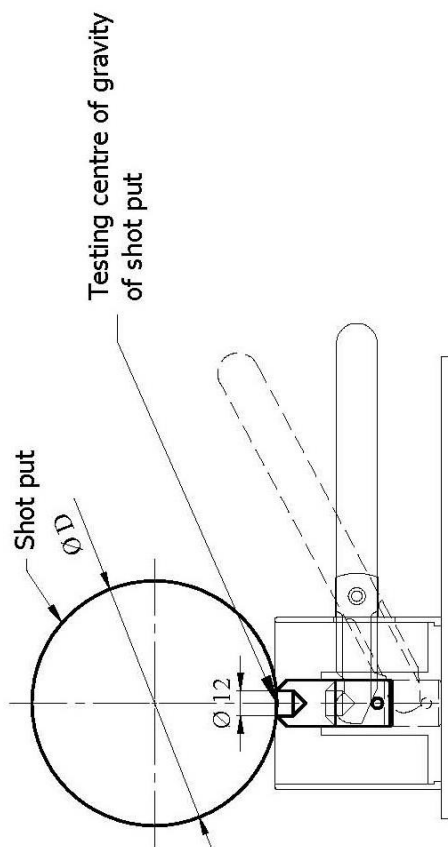

The centre of the shot put gravity must be situated not more than 6 mm from the centre of the sphere.
 The shot put is tested on the horizontal sharp-edged circular orifice 12 mm in diameter.

The shot put specifications according to the IAAF rules

Minimum weight for admission to competition and acceptance of a record	3.000 kg		4.000 kg		5.000 kg		6.000 kg		7.260 kg	
	min.	max.	min.	max.	min.	max.	min.	max.	min.	max.
Information for manufacturers: Range for supply of implement for competition	3.005 kg	3.025 kg	4.005 kg	4.025 kg	5.005 kg	5.025 kg	6.005 kg	6.025 kg	7.265 kg	7.285 kg
Diameter of shot put [$\varnothing D$]	85 mm	110 mm	95 mm	110 mm	100 mm	120 mm	105 mm	125 mm	110 mm	130 mm

Table no. 3

VII. Measuring discuses

For testing discuses we use: the electronic scales for checking the weight (see the instruction manual of the scales) and the callipers for measuring thickness and diameters (see Table no. 4 below).

The discus specifications according to the IAAF rules						
Minimum weight for admission to competition and acceptance of a record	1.000 kg		1.500 kg		2.000 kg	
	min.	max.	min.	max.	min.	max.
Information for manufacturers: Range for supply of implement for competition	1.005 kg	1.025 kg	1.505 kg	1.525 kg	1.755 kg	2.005 kg
Outside diameter of metal rim [ϕ D]	180 mm	182 mm	200 mm	202 mm	210 mm	212 mm
Diameter of metal plane or flat centre area [ϕ d]	50 mm	57 mm	50 mm	57 mm	50 mm	57 mm
Thickness of metal plate or flat centre area [G]	37 mm	39 mm	38 mm	40 mm	41 mm	43 mm
Thickness of metal rim (6 mm from edge) [g]	12 mm	13 mm	12 mm	13 mm	12 mm	13 mm

Table no. 4

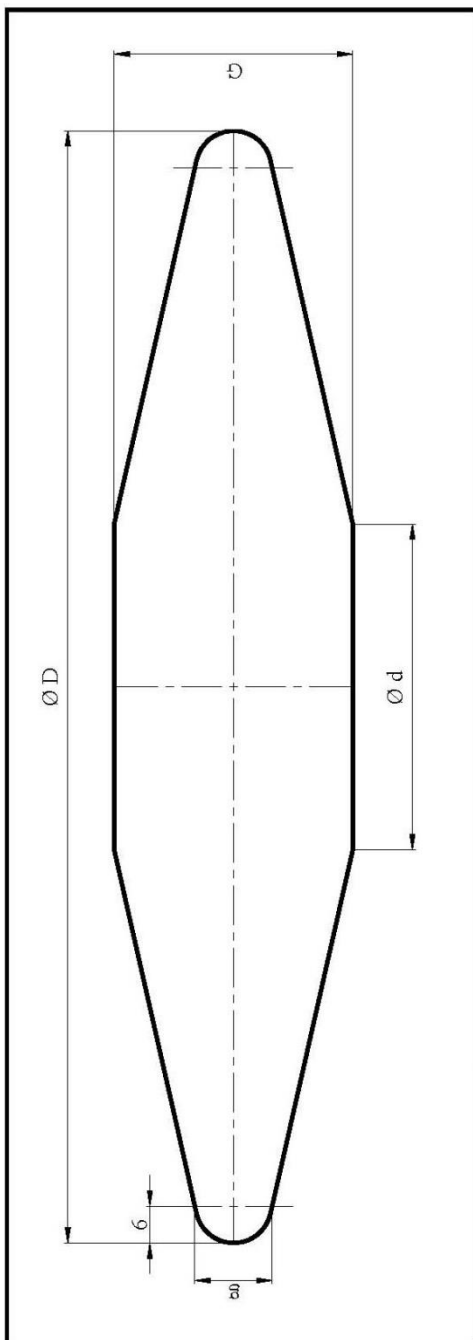

VIII. Operation and maintenance

Throwing implements get dirty during training and competitions, so they should be cleaned (with cloth or brush) before testing. If all implements are dry and dirt-free for tests, the devices included in the set will be also clean. Dirt may influence the precision of the measuring devices. If the elements of the measuring devices are dirty, first use a vacuum cleaner to remove loose dirt and then wipe the elements with a cloth (or brush).

The set ought to be stored in a dry place, preferably in room temperature.

We would be grateful for comments and opinions about operating ZP-S287.

Please send them directly to:

p.ciechanowski@polanik.com

Pawel Ciechanowski

Product Manager

Even the best technical solutions cannot substitute for common sense. The product should be used according to this instruction manual. The producer shall not be liable for any incidents caused by misuse of the product. The producer reserves the right to introduce without warning changes in product constructions and colours.

We wish you satisfaction from using Polanik products

Your Polanik Team