

POLANIK
Poland, Życzliwa 11
97-300 Piotrków Trybunalski

tel. +48 44 646 44 81
tel. +48 44 648 50 89
fax +48 44 646 43 58

e-mail: info@polanik.com
www.polanik.com



TECHNICAL SPECIFICATION INSTRUCTION MANUAL

Competition steel-aluminium collapsible hurdle

PP-171/6d



File: 2019-02-26
PRODUCT SUPPORT
Paweł Ciechanowski
p.ciechanowski@polanik.com

I. General description and use

PP-171/6d is a resistant to weather, inexpensive in transport and high quality competition hurdle, which is designed for national and international competitions.

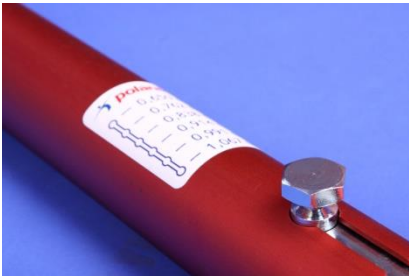

II. Technical specification

Code	PP-171/6d
Hurdle type	competition collapsible certified
(A) Top board	plastic, with inside ribbing
(B) Telescope tube	aluminium anodized or powder painted* in red, spring-loaded button system of height adjustment
(C) Frame	steel galvanized
(D) Feet	aluminium anodized or powder painted* in red, spring-loaded button system of counterweight selection, counterweights installed on stainless steel balls
Heights [mm]	650
	762
	838
	914
	991
	1067
Weight [kg]	13

*There may be differences in hue between the telescope tubes and the hurdle feet.

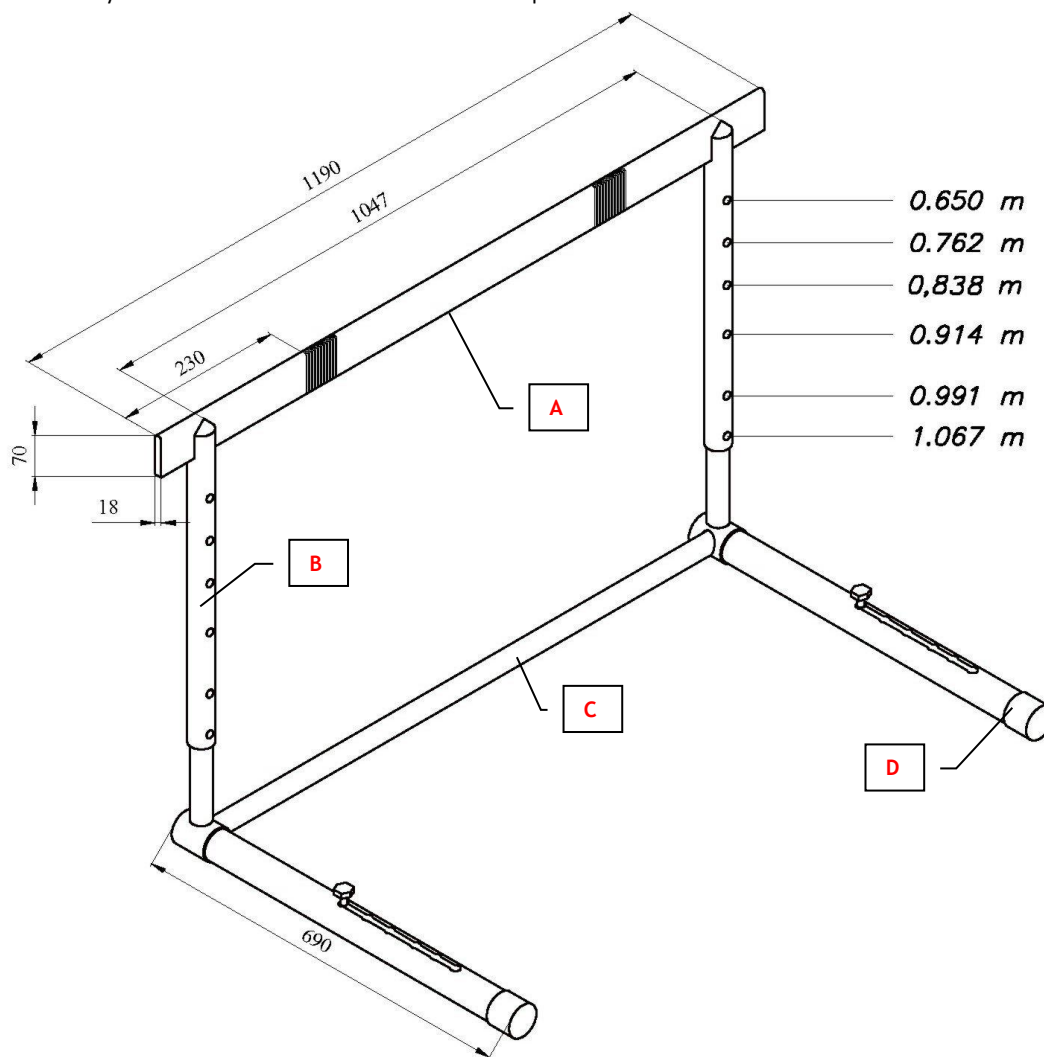





III. Packing and transport

The hurdles are put on pallets in parts (frames, feet and foot screws separately) and wrapped with foil.

Package type		foiled pallet
Dim. [cm]	contents	18 pcs
	length	120
	width	80
	height	100
Volume m ³		0,96
Gross weight [kg]		260

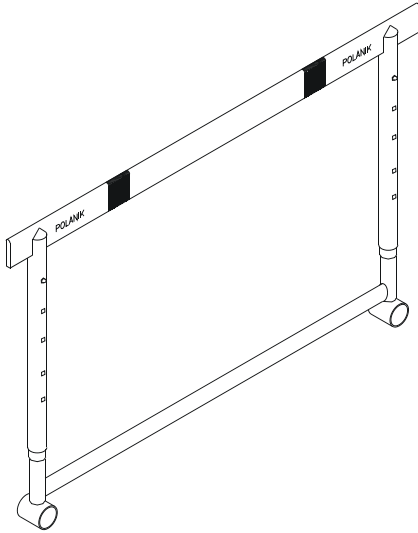
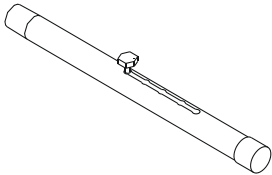
IV. Parts list (part sets)

Item	Part/set description	Q-ty pcs	Sketch
1	Hurdle frame	1	
2	Hurdle foot	2	
3	Washer	2	
4	Foot screw	2	

V. Assembly

A wrench 17 is needed to perform the assembly. Although one person can prepare the hurdle for use, a convenient and fast assembly process requires two persons.

To assemble the hurdle please do the following:

- slide carefully one hurdle foot (item 2) into one frame socket (item 1),
- make sure the foot (item 2) is properly placed in the socket, if it is not straight, please correct its position,
- screw the foot (item 2) to the hurdle frame (item 1) by means of the foot screw (item 4) and the washer (item 3),
- install the other foot in the same way.

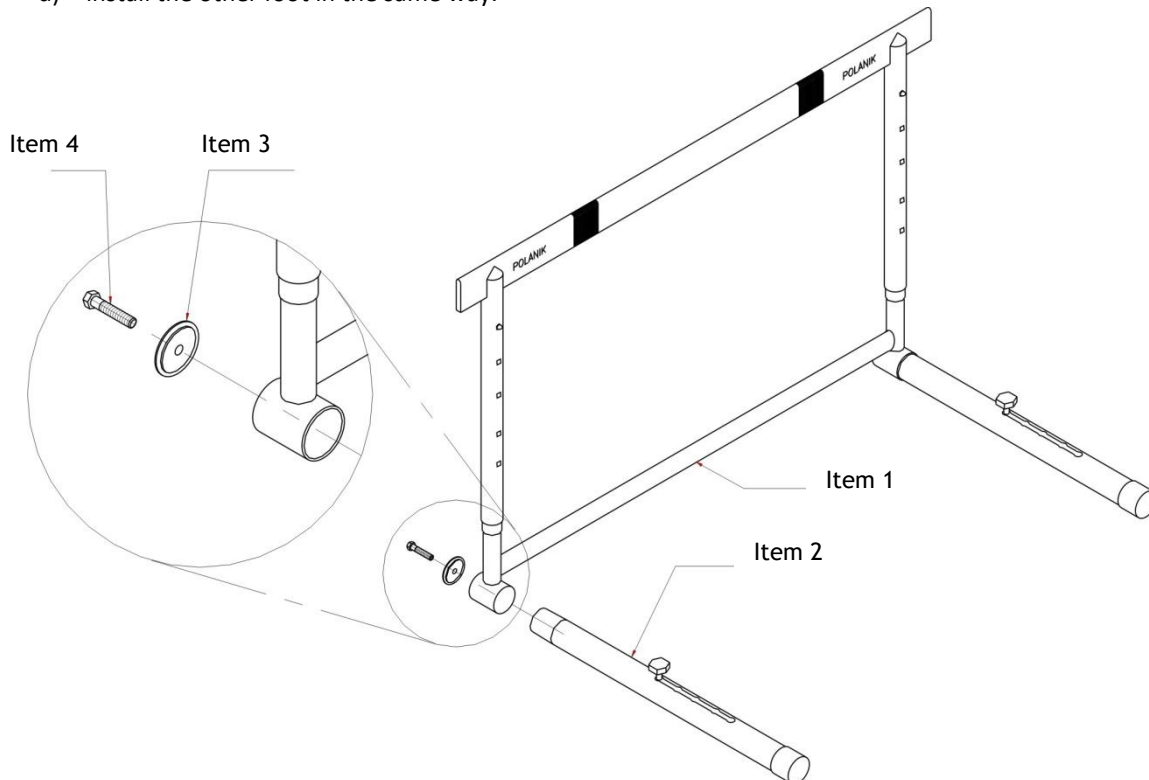

The main goal of the hurdle collapsible construction is to assure easy and cheap transport. Note that once you screw the feet down, the hurdle is practically non-dismountable. Therefore we do not recommend unscrewing the hurdle feet during idle periods. Removing the feet without proper tools can cause serious hurdle damages which Polanik shall not be liable for.

VI. Operation and maintenance

The height adjustment is done as follows:

- a) while holding the telescope tubes press the spring-loaded buttons simultaneously,
- b) slide the telescopes down or up to adjust the height until the buttons click,

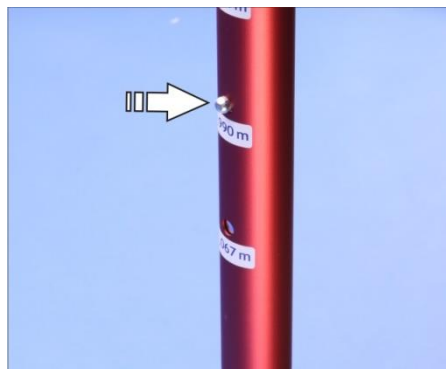

- c) next the hurdle toppling force should be adjusted accordingly, so press and hold the knob in the hurdle foot,



- d) then slide the counterweight to the corresponding height according to the label, then release the knob, do the same with the other hurdle foot.

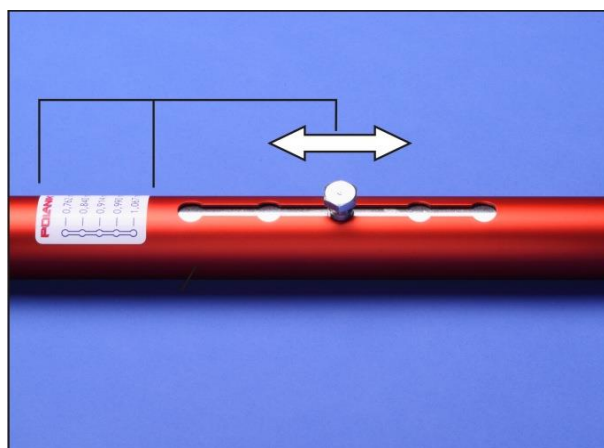

During idle periods the hurdles must be stored in a roofed dry place. For optimal performance they should be stored and transported on Polanik hurdle carts: HC-23 and HC-34.

After every athletics season the hurdles must be cleaned from sand (mud, dust and etc). Special attention is required for the counterweight sliding mechanisms, which should be dismounted, cleaned and greased.

Before you begin the maintenance work, you should gather the following items:

- hurdle foot plastic plug for PP-171 (2 pcs for each hurdle) code: S-0008-001-00-00-05,
- grease (approx. 50g for each foot),
- wrench 19,
- hex key 5.

The counterweight disassembly is done as follows:

- push down the foot catch and slide it toward the plastic plug,
- put hex key into the bolt M6 through the technological hole under the foot,
- hold the foot catch bolt with wrench 19 and unscrew the bolt M6 with the hex key,

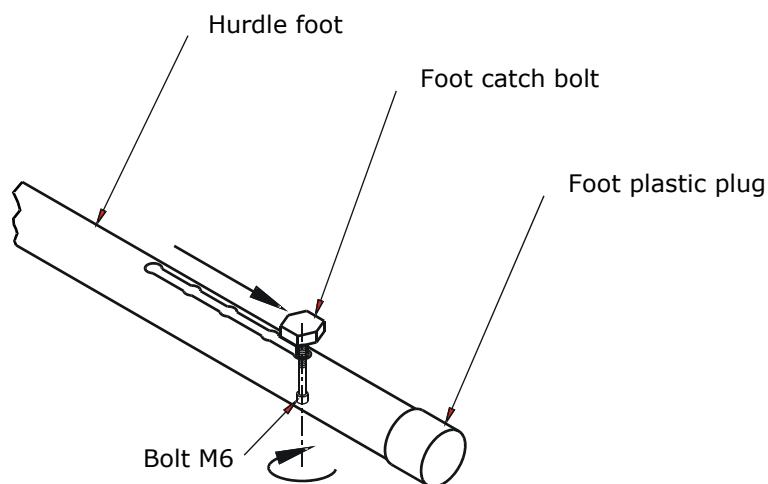

- remove the foot catch bolt and the spring from the counterweight,
- remove the foot plastic plug from the foot tube (it often happens that the plug is damaged while removing, that is why the spare plugs should be purchased before the disassembly)

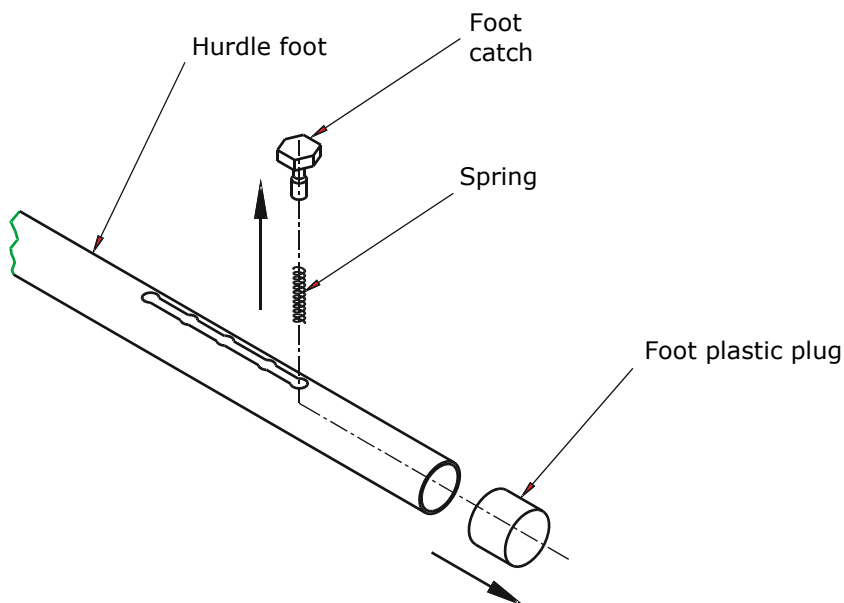

f) **slide out the counterweight carefully – pay attention to the stainless steel bearing balls installed in the bottom of the counterweight – they may fall out**, and remove the bolt M6,

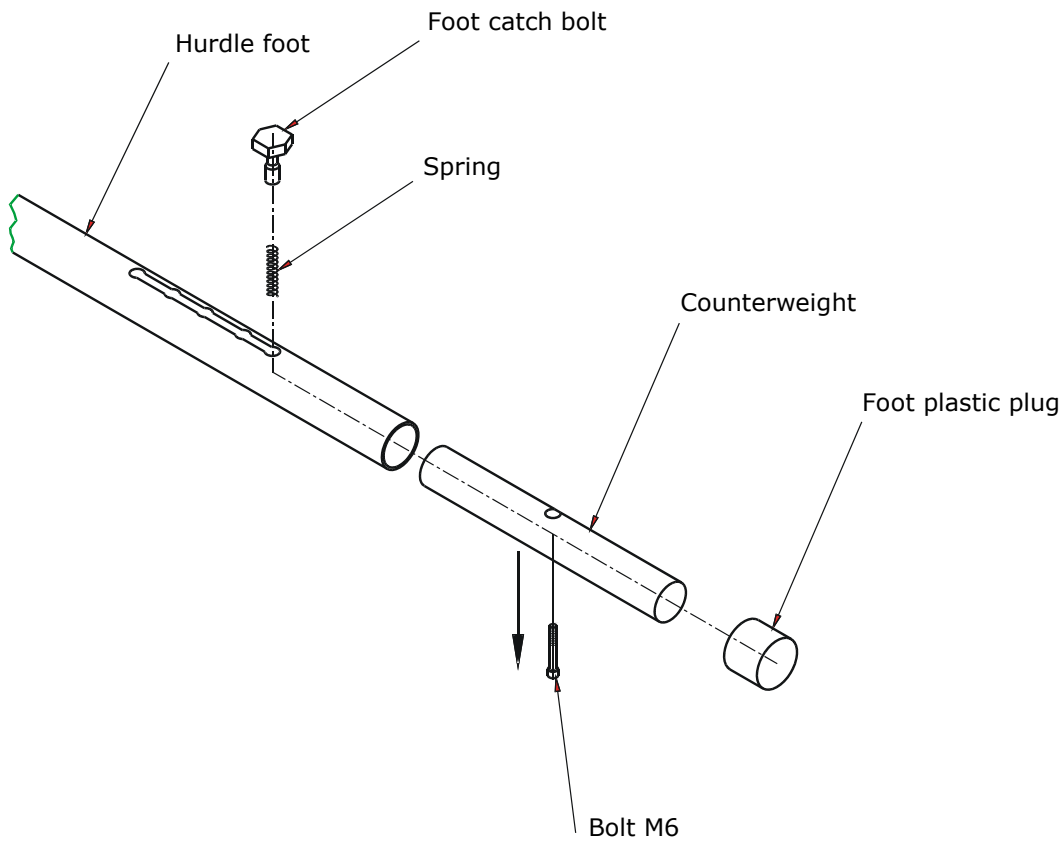

g) take out the balls from their sockets,

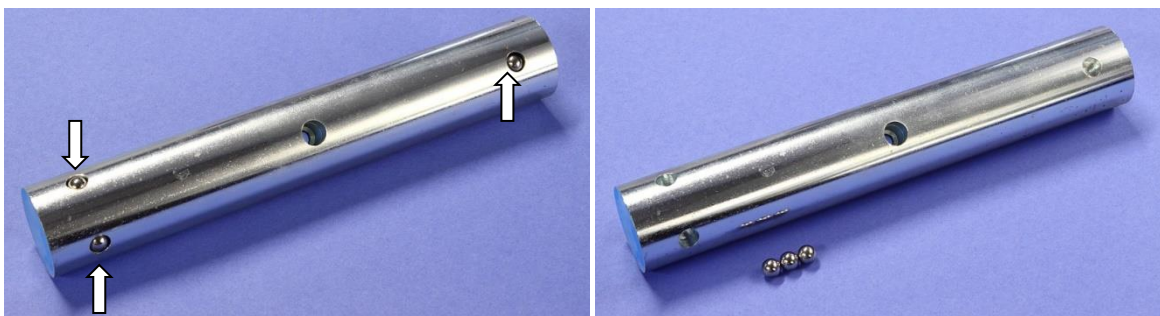

h) the counterweight, the ball sockets and the inside of the foot tube should be cleaned from dirt and old grease,

i) grease the inside of the ball sockets and install the balls,

j) slide in the counterweight carefully,

k) the assembly process is done in the reverse sequence.

VII. IAAF Certificate

International Association of Athletics Federations



Product Certificate

The IAAF is pleased to certify hereby that the following product:

Product's Trade Name:	Hurdle, Competition
Description, Colour / Absolute Thickness:	Steel, aluminium, Red/metallic
Company Name, Country:	Polanik Sp. z o. o. - Sp. K., POL
Catalogue Number:	PP-171/d
IAAF Certification Number:	E-10-0616

meets the dimensional requirements for use in all international athletics competitions.

It is for the purchaser to determine the item's fitness for the purpose based on his knowledge of the local conditions and use.

Valid from:	1 February 2019
Until the last day of:	February 2023

This certificate is issued in accordance with the terms and conditions of the IAAF Certification System of track and field facilities, implements and competition equipment.



JORGE SALCEDO
IAAF Technical Committee Chairman

