

POLANIK  
Poland, Życzliwa 11  
97-300 Piotrków Trybunalski

tel. +48 44 646 44 81  
tel. +48 44 648 50 89  
fax +48 44 646 43 58

e-mail: [info@polanik.com](mailto:info@polanik.com)  
[www.polanik.com](http://www.polanik.com)



## **ASSEMBLY MANUAL** **Modular grid platforms**

**ST-5x4**  
**ST-6x5**  
**ST-7x5**  
**ST-8,5x6**  
**ST-9x7**

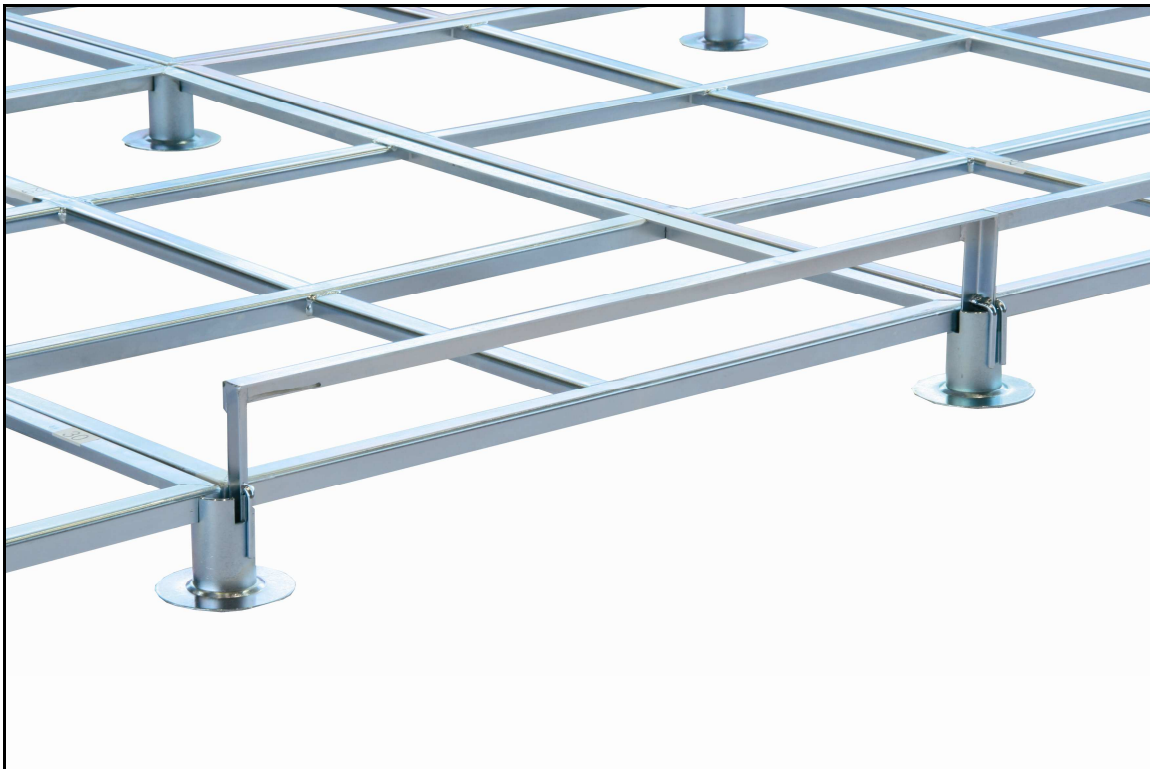

File: 2014-07-18  
PRODUCT SUPPORT  
Pawel Ciechanowski  
[p.ciechanowski@polanik.com](mailto:p.ciechanowski@polanik.com)

Thank you for choosing Polanik modular grid platforms.

## Contents

Chapter	Page
I. General description and use	2
II. Parts list	2
III. Assembly	2
IV. Maintenance	3
V. Platform cart WSZG-30 (option)	3
VI. Assembly plans	4
ST-5x4	4
ST-6x5	5
ST-7x5	6
ST-8,5x6	7
ST-9x7	8

### I. General description and use

Modular grid characteristics:

- innovative construction – small and light modules, which are easy to transport and position in situ, take little storage space,
- high durability and quality – all grid elements are made of galvanized steel, universal elements can be used to form other platforms of different dimensions,
- easy operating – very quick assembly and disassembly processes done by two people take approx. 30 minutes.

### II. Parts list

The quantity and types of the elements which form the platforms are described in the respective assembly plans. The standard platform element (1 m x 1 m) marked in the plans as element "o" is not labelled. The remaining element types are labelled with numbers which correspond to the markings in the plans.

### III. Assembly

The assembly is done according to the assembly plans included in this manual. You do not need to prepare any special tools to assemble the modular grid platform. However it is recommended that you should have a measuring tape at hand to position the first row before the pole vault box. The elements in front of the rear side of the pole vault box should be positioned in the distance of 250 mm (see the assembly plans). Next the steel guards (1 or 2 depending upon the platform model) are put on the elements (see the drawing below). The steel guards prevent the vaulting pole from going under the platform.

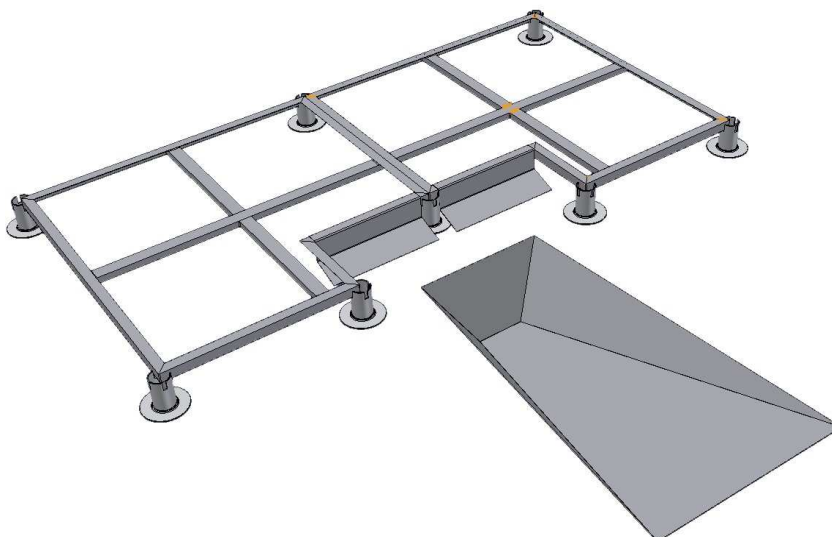

Grid platform elements are installed on linking feet. Each foot has got 4 cut-outs by means of which you can link 4 element corners together (see images below).



If you have linked all the base elements you can start to install railings which secure the landing area on the platform. The railings are also slid into linking feet. They are installed on the right, the left and at the back of the platform.



#### **IV. Maintenance**

During longer idle periods the grid must be disassembled and stored indoors. Periodical inspections should be executed after every athletics season. Any revealed damages ought to be protected with anticorrosive paint.

#### **V. Platform cart WSZG-30 (option)**

We recommend using Polanik cart WSZG-30 available as an option (apart from ST-9x7 and ST-8,5x6 which come with 2 carts) for transporting and storing the platform. Since the cart is equipped with a universal platform (100 cm x 92,5 cm) and a handy container, it can be used for other purposes.



Even the best technical solutions cannot substitute for common sense. Operating sports equipment should be taken place under qualified staff supervision. The producer shall not be liable for any incidents caused by improper assembly or misuse.

# ST-5x4

35 stopek / feet

10 barierek / barriers

14 elementów "0" / elements "0"

2 elementy "3" / elements "3"

2 elementy "23" / elements "23"

2 nakładki zabezpieczające / steel guards

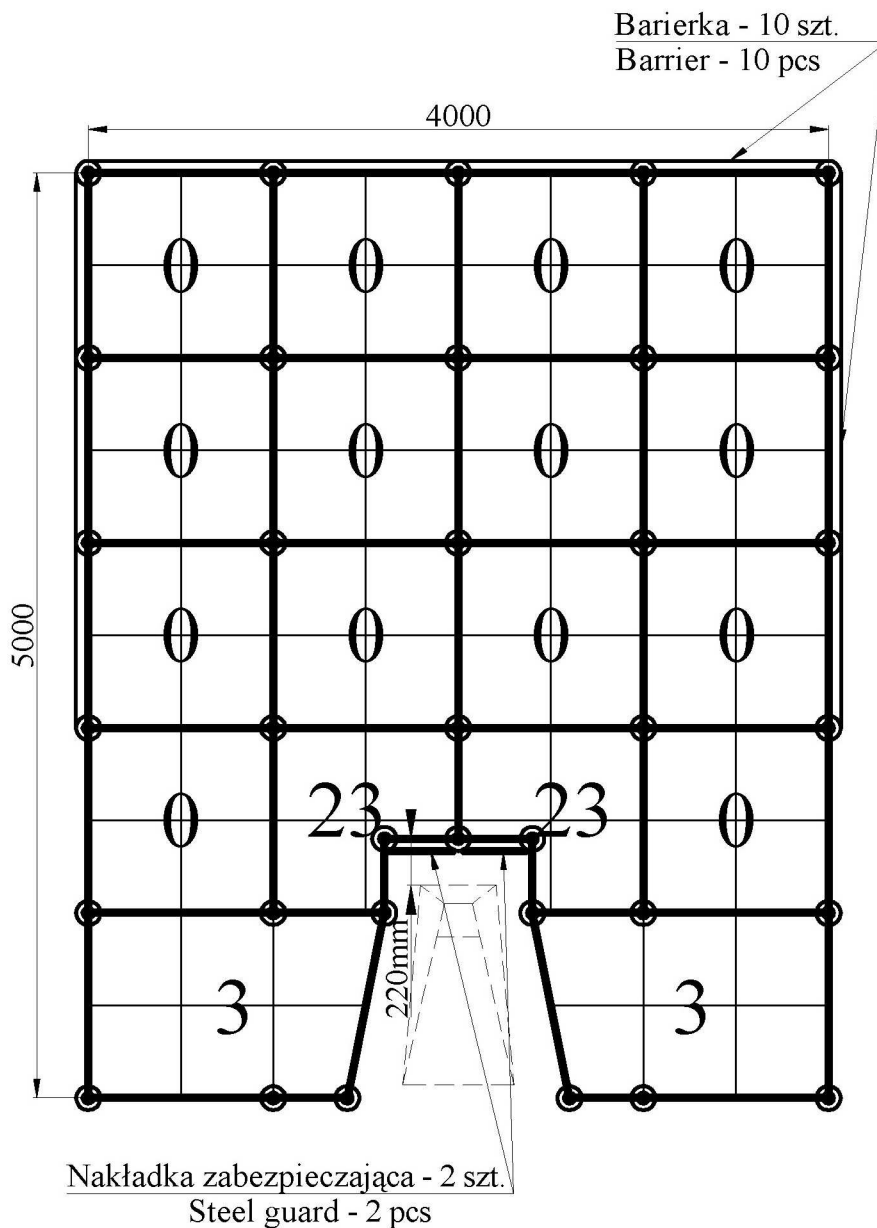

Schemat montażu stelaża ST-5x4

Assembly plan of steel galvanized mat grid ST-5x4

# ST-6x5

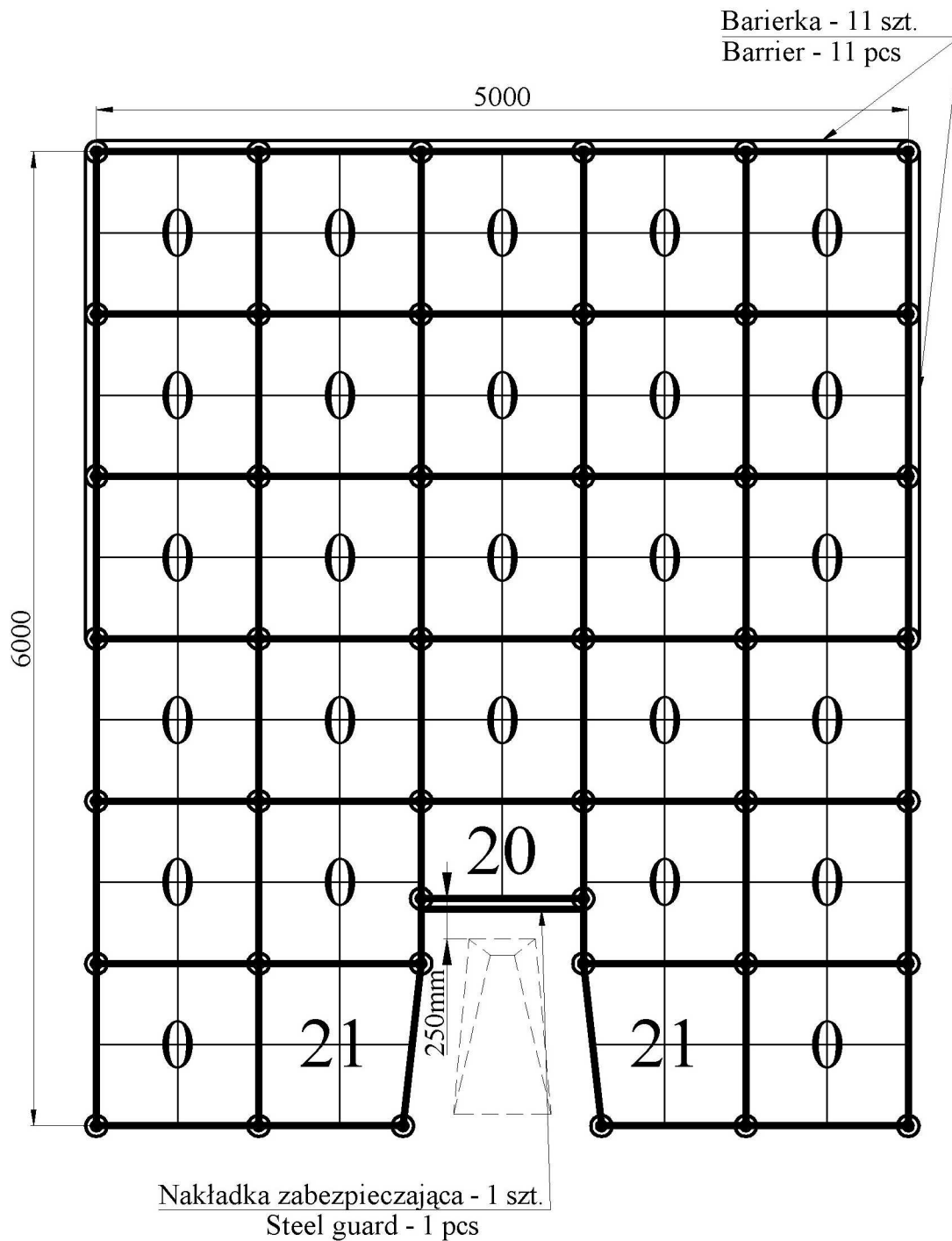

Schemat montażu stelaża ST-6x5  
Assembly plan of steel galvanized mat grid ST-6x5

# ST-7x5

Barijerka - 13 szt.  
Barrier - 13 pcs

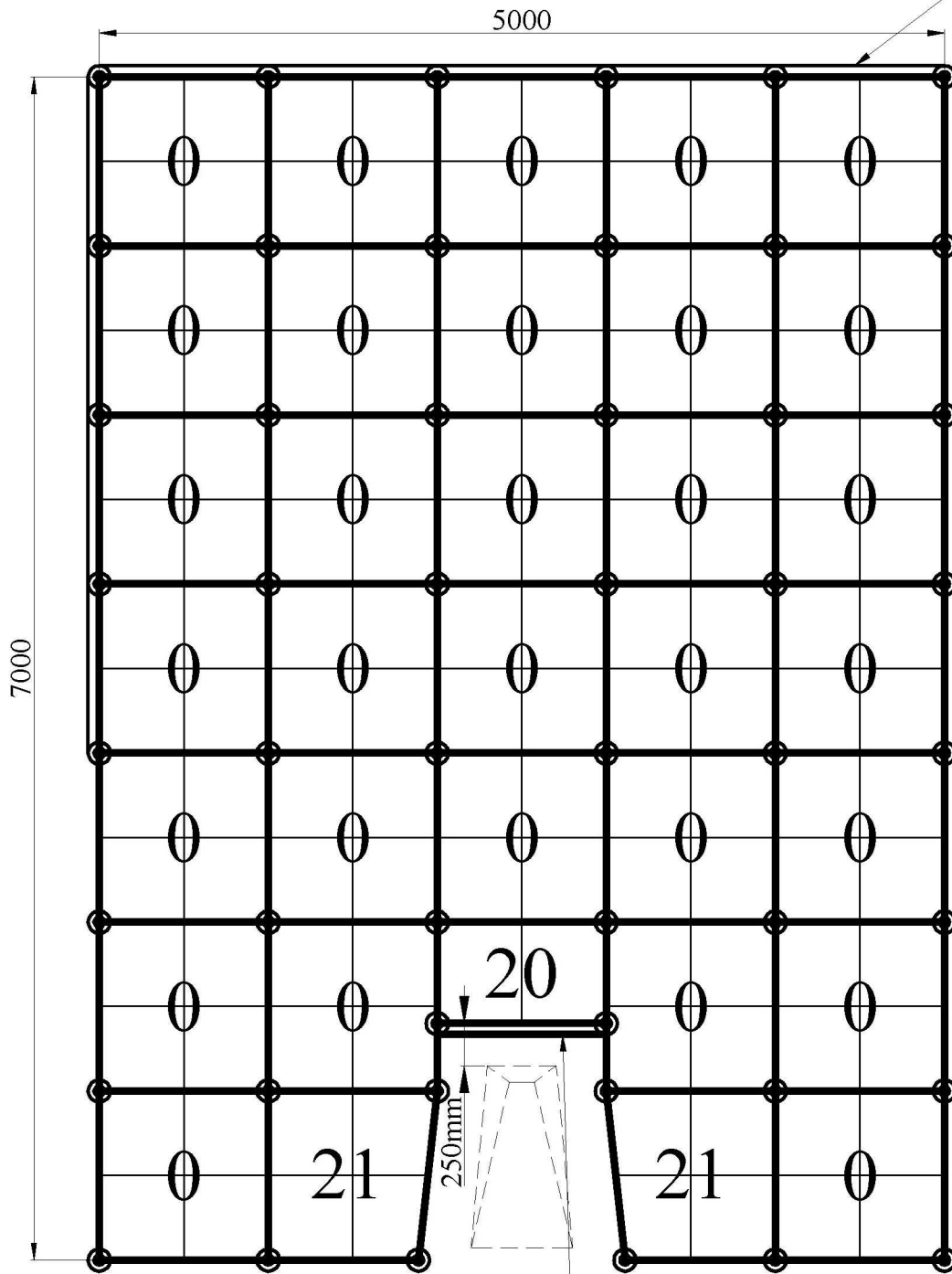

Nakładka zabezpieczająca - 1 szt.  
Steel guard - 1 pcs

Schemat montażu stelaża ST-7x5  
Assembly plan of steel galvanized mat grid ST-7x5

# ST-8,5x6

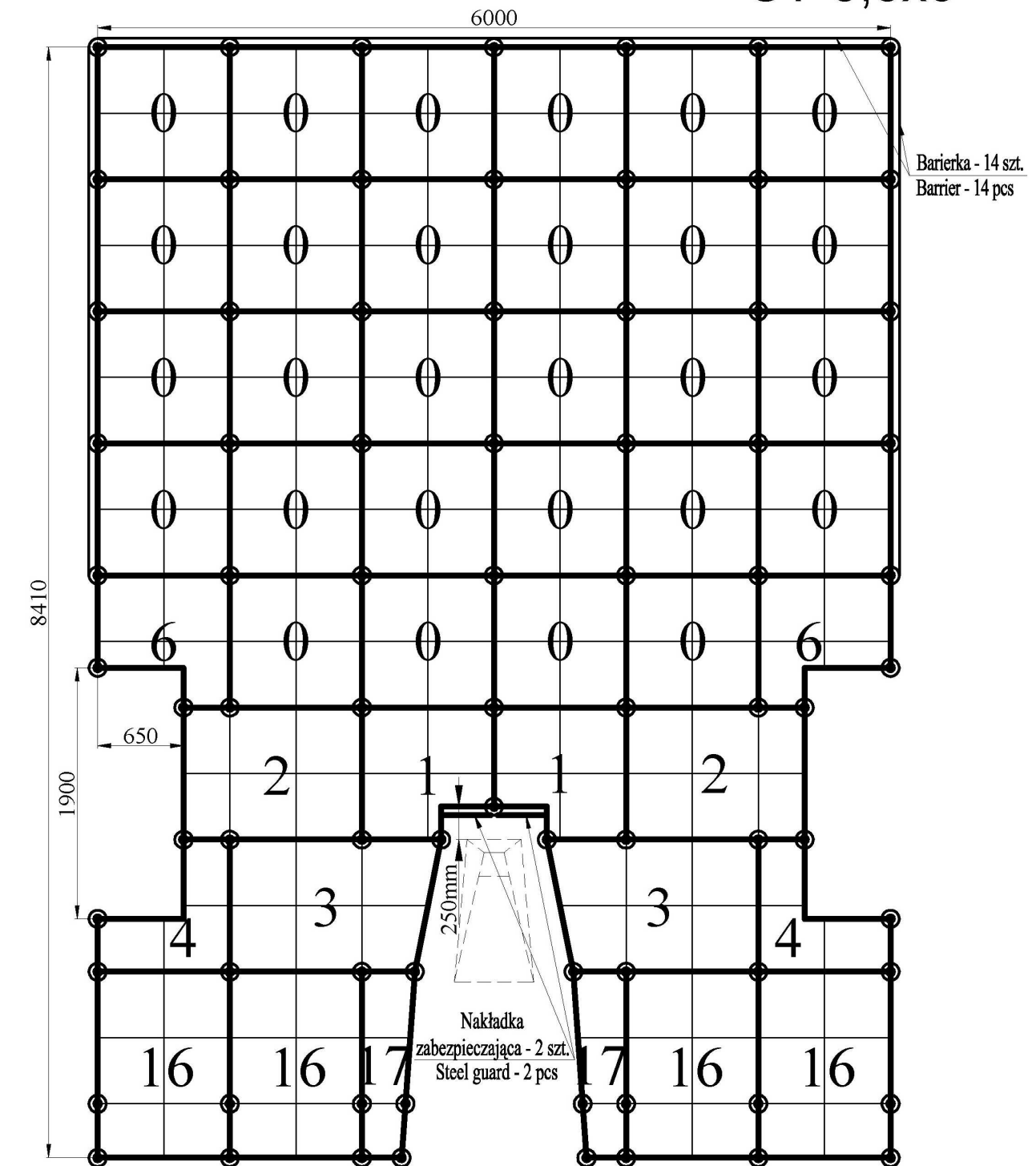

## Uwaga !

Układanie stelaża rozpoczynać od segmentów "1" przy skrzynce tyczki

## Attention !

Mat grid elements should be sited according to the above diagram, start from segment no. 1 at the pole vault box

## Schemat montażu stelaża ST-8,5x6 Assembly plan of steel galvanized mat grid ST-8,5x6

Zawiera 2 wózki WSZG-30 w standardzie. Comes with 2 platform carts WSZG-30.

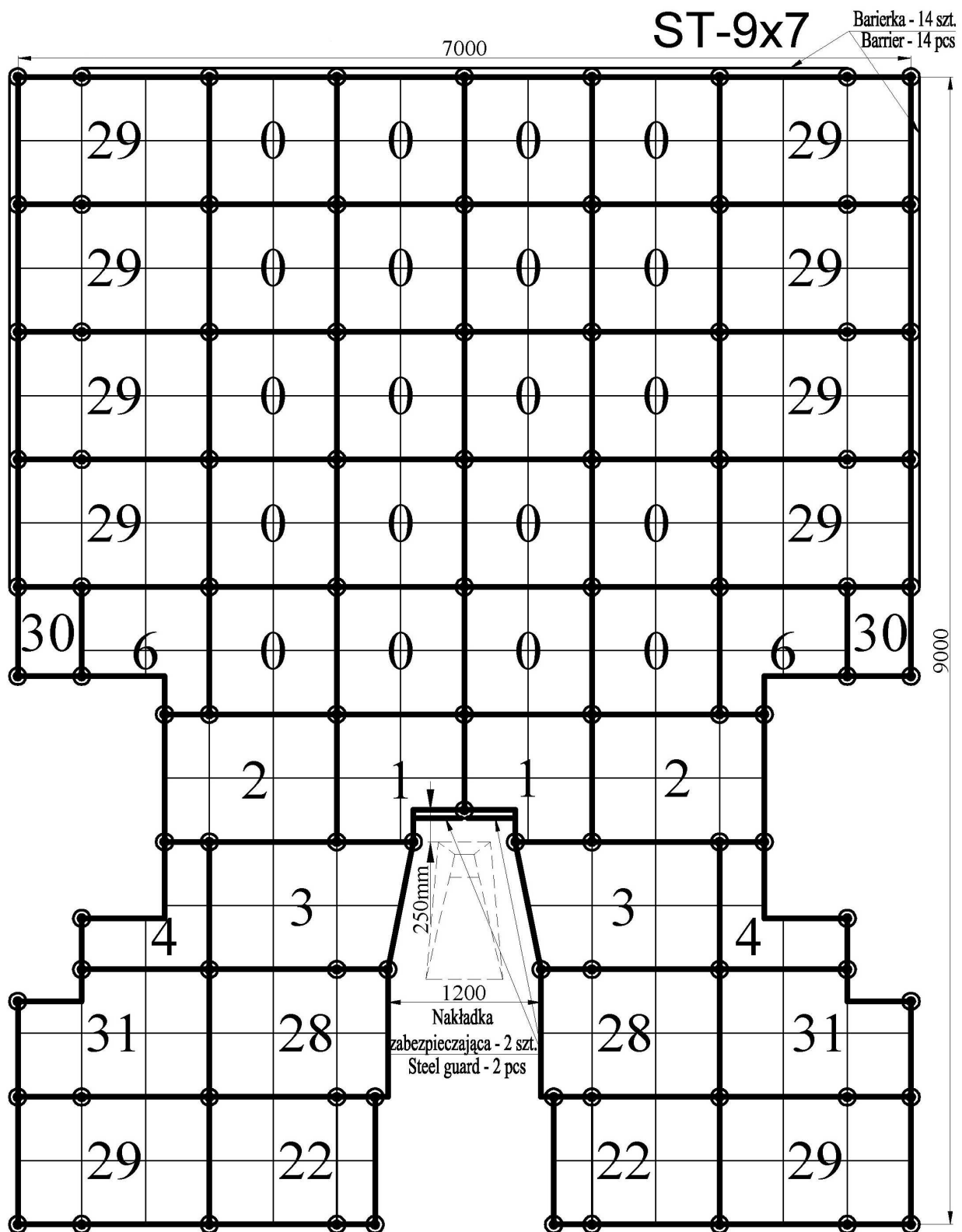

**Uwaga !**

Układanie stelaża rozpoczynać od segmentów "1" przy skrzynce tyczki

**Attention !**

Mat grid elements should be sited according to the above diagram, start from segment no. 1 at the pole vault box

**Schemat montażu stelaża ST-9x7**

**Assembly plan of steel galvanized mat grid ST-9x7**

*Zawiera 2 wózki WSZG-30 w standardzie. Comes with 2 platform carts WSZG-30.*