

POLANIK  
Poland, Życzliwa 11  
97-300 Piotrków Trybunalski

tel. +48 44 646 44 81  
tel. +48 44 648 50 89  
fax +48 44 646 43 58

e-mail: [info@polanik.com](mailto:info@polanik.com)  
[www.polanik.com](http://www.polanik.com)



## **TECHNICAL SPECIFICATION** **INSTRUCTION MANUAL**

### **Timers and judges stand**

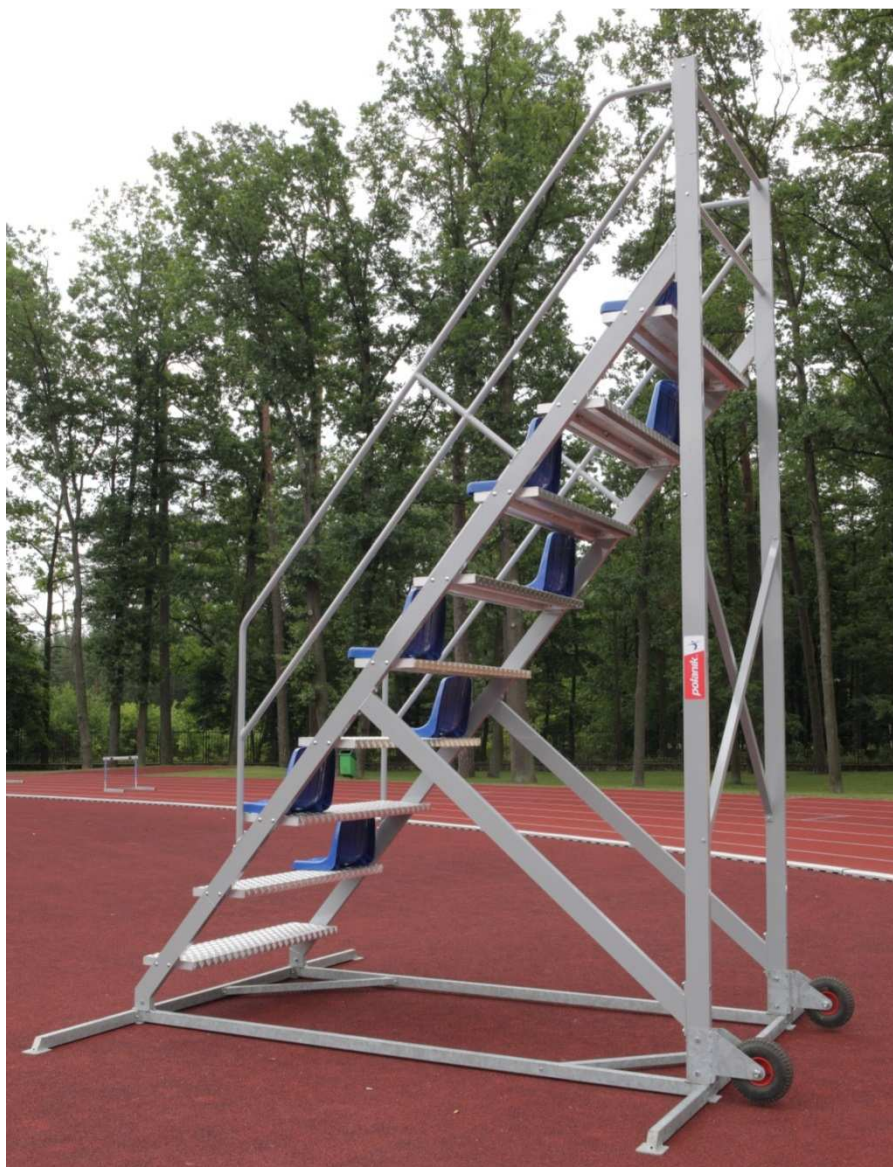

File: 2015-02-23

PRODUCT SUPPORT  
Paweł Ciechanowski  
[p.ciechanowski@polanik.com](mailto:p.ciechanowski@polanik.com)

Thank you for choosing POLANIK.

## Contents

Chapter	Page
I. General description and use	3
II. Technical specification	3
III. Assembly	4
IV. Operation	7
V. Maintenance	7
VI. Declaration	8



## I. General description and use

SCH-8 is a stand designed for track events. The stand is used for hand timing during athletics competitions. The product is designed in the way which ensures good visibility of the start line and the finish line for all timekeepers.

## II. Technical specification

The support construction and the steps are made of aluminium. The steel base with two wheels is hot galvanized. The high backrest 8 seats are made of durable plastic. The stand is sent to a customer in parts. The package dimensions are: 4500 x 1000 x 600 [mm]. The weight is approx. 150 kg.

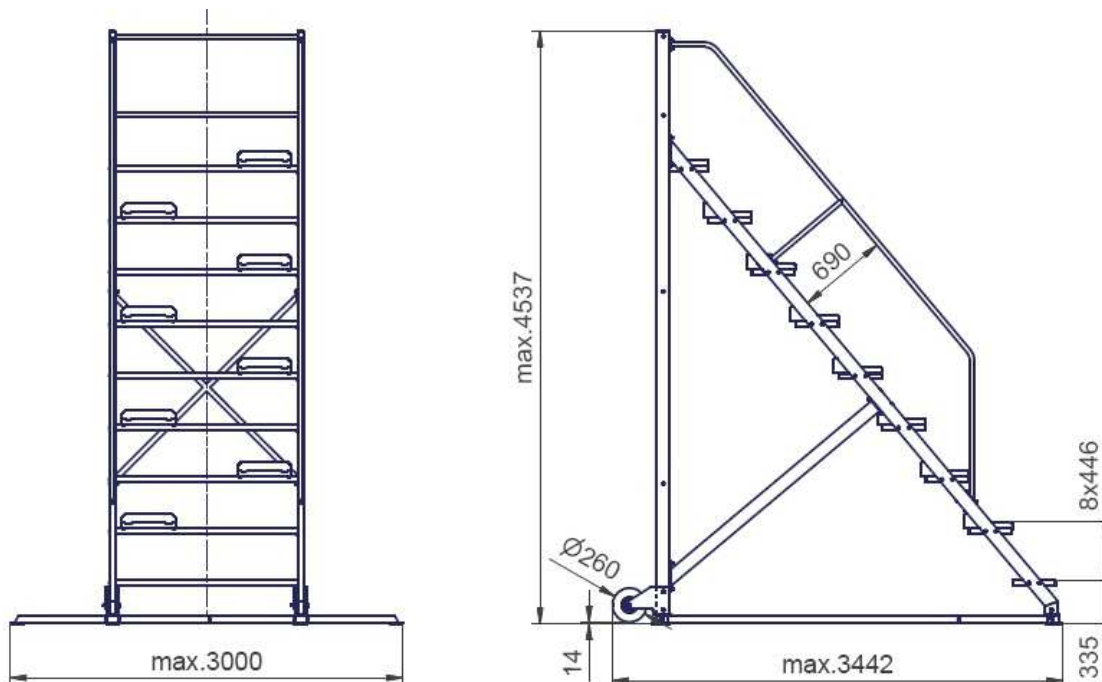

[mm]

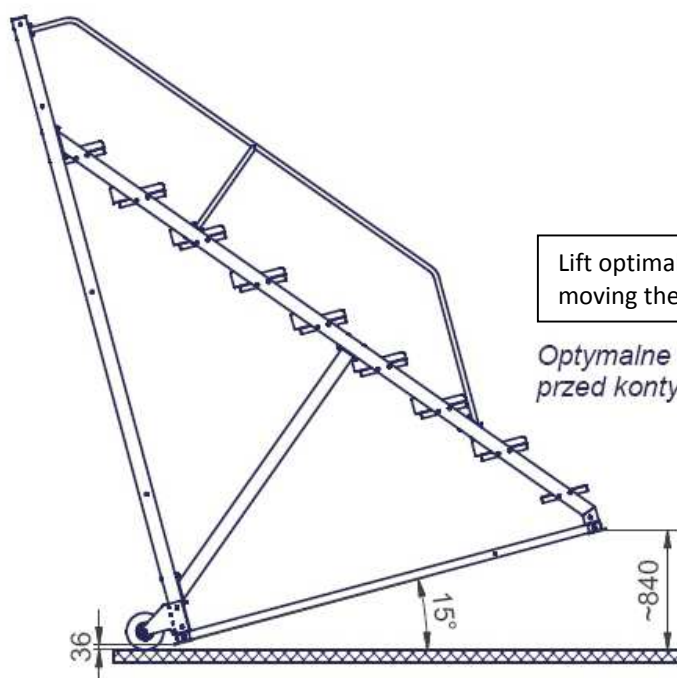

Lift optimally the construction before moving the stand

*Optymalne uniesienie konstrukcji przed kontynuowaniem jazdy*

### III. Assembly

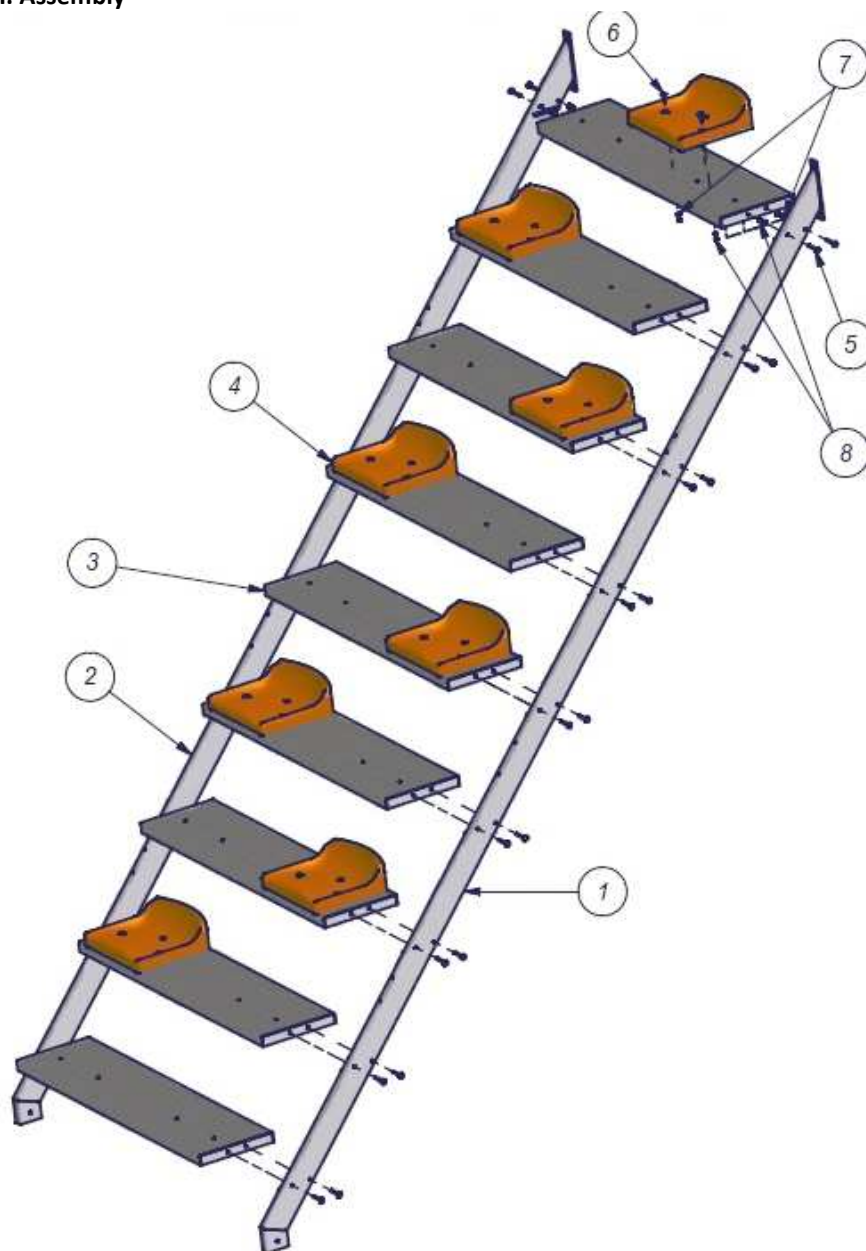

Item	Q-ty	Description
8	52	Self-locking nut M8
7	52	Washer 8,4
6	16	Carriage bolt M8x30
5	36	Carriage blot M8x60
4	8	Seat
3	9	Step
2	1	Side arm left
1	1	Side arm right

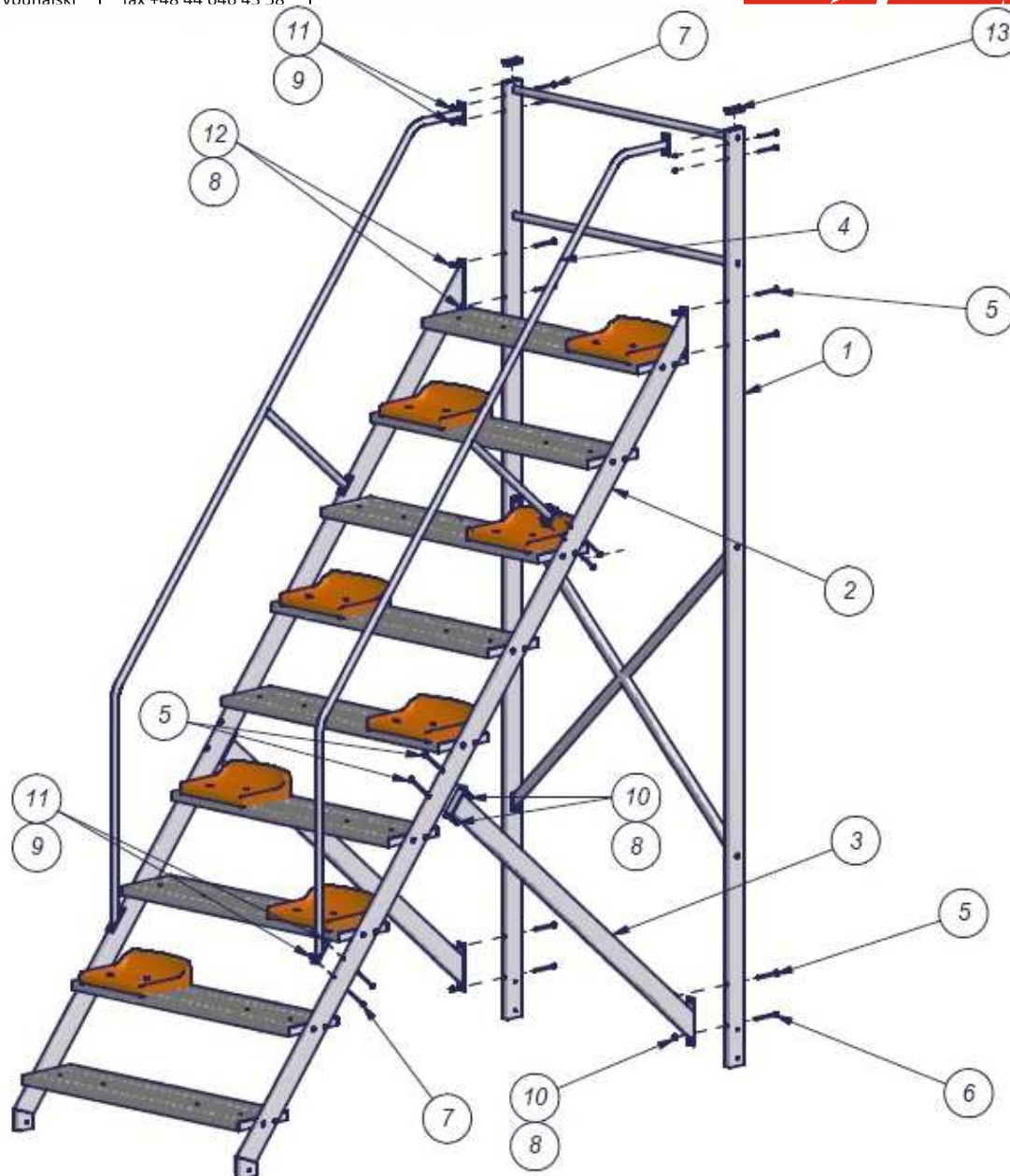

Item	Q-ty	Description
13	2	Blanking cap 100x40
12	4	Cap nut M10
11	12	Cap nut M8
10	8	Self-locking nut M10
9	12	Washer 8,4
8	12	Washer 10,5
7	12	Screw M8x120
6	2	Screw M10x130
5	10	Screw M10x120
4	2	Rail
3	2	Support
2	1	Ramp
1	1	Back supporting frame

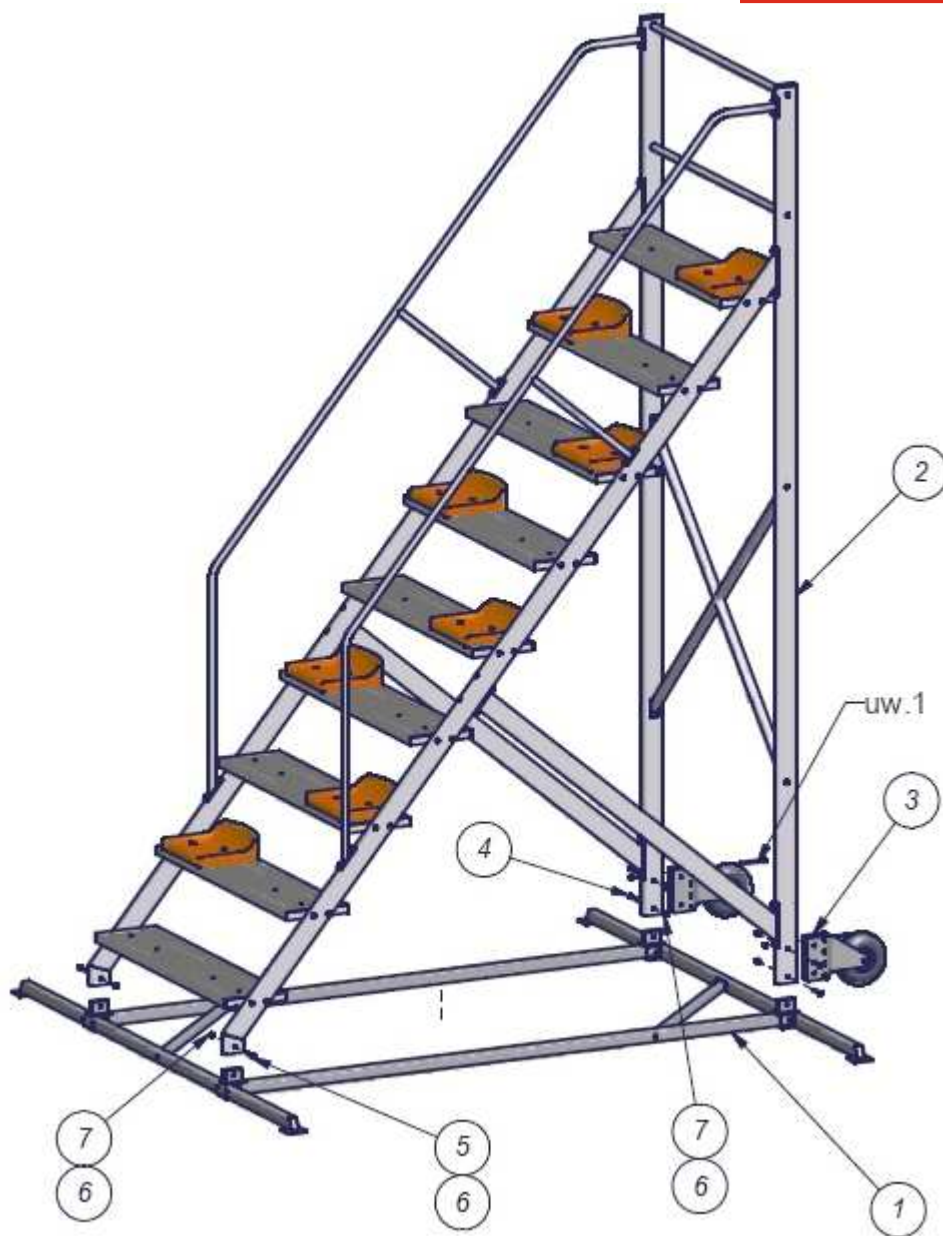

Item	Q-ty	Description
7	6	Nut M12
6	8	Washer 13
5	2	Screw M12x60
4	4	Screw M12x70
3	2	Wheel
2	1	Top construction
1	1	Steel base



The product is equipped with wheels for easy positioning the stand. Before you move the product please lift the construction as shown below approx. 840 mm above the ground and then start to position the stand.

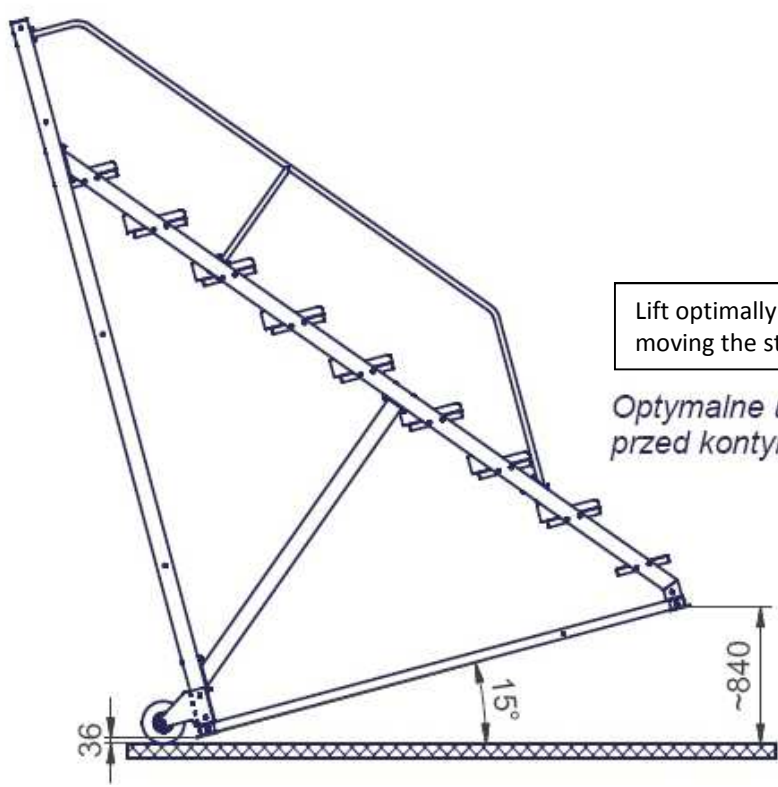

Lift optimally the construction before moving the stand

*Optymalne uniesienie konstrukcji przed kontynuowaniem jazdy*

**V. Maintenance**

When not used the stand must be stored in a dry roofed place.

**VI. Declaration**  
POLANIK  
Poland, Zyczliwa 11  
97-300 Piotrków Trybunalski

tel. +48 44 646 44 81  
tel. +48 44 648 50 89  
fax +48 44 646 43 58

e-mail: info@polanik.com  
[www.polanik.com](http://www.polanik.com)



- 1) No. 2015-02-23  
2) Issuer's name: POLANIK  
Issuer's address: Zyczliwa 11, 97-300 Piotrkow Tryb.  
3) Object of declaration:

No.	Description of goods	Code
1	Timers and judges stand	SCH-8

4) The object of declaration described above is in conformity with the Polanik company production norms.

Additional Information

5) Declaration for:  
Buyer/Distributor/User

Signed for and in behalf of:

POLANIK  
2015-02-23 Piotrkow Tryb.  
(Date and place of issue)

6) Pawel Ciechanowski  
Product Manager

.....  
(Name, function)

.....  
(Signature or equivalent authorized by the issuer)